

MOUNTING AND OPERATING INSTRUCTIONS



EB 2046 EN

Translation of original instructions



Safety Temperature Limiters (STL) with Type 2212 Safety Thermostat

Safety Temperature Limiters (STL) with Type 2212 Safety Thermostat Self-operated Regulators

Edition July 2024



Note on these mounting and operating instructions

These mounting and operating instructions assist you in mounting and operating the device safely. The instructions are binding for handling SAMSON devices. The images shown in these instructions are for illustration purposes only. The actual product may vary.

- For the safe and proper use of these instructions, read them carefully and keep them for later reference.
- If you have any questions about these instructions, contact SAMSON's After-sales Service (aftersaleservice@samsongroup.com).



Documents relating to the device, such as the mounting and operating instructions, are available on our website at www.samsongroup.com > **Downloads > Documentation.**

Definition of signal words

DANGER

Hazardous situations which, if not avoided, will result in death or serious injury

WARNING

Hazardous situations which, if not avoided, could result in death or serious injury

NOTICE

Property damage message or malfunction

Note

Additional information

Tip

Recommended action

1	General safety instructions	4
2	Process medium and scope of application	5
3	Transportation and storage	5
4	Design and principle of operation	5
5	Installation	6
5.1	Installing the valve.....	8
5.2	Strainers	8
5.3	Additional mounting instructions	8
5.4	Temperature sensor	8
5.4.1	Capillary tube	9
5.5	Additional electric unit.....	9
5.5.1	Electric signal transmitter	9
6	Start-up and operation	9
6.1	Limit adjustment	9
6.2	Unlocking after a fault	10
6.3	Special version of Type 2401 Pressure Element.....	11
6.3.1	Unlocking the Type 2401 Pressure Element.....	11
6.4	Servicing.....	11
6.5	Disposal.....	12
6.6	Returning devices to SAMSON	12
7	Certificates	13
7.1	Information on the UK sales region.....	13
8	Markings on the device	20
8.1	Nameplate of Type 2212 Safety Thermostat	20
8.2	Valve nameplate	20
8.3	Location of the nameplate.....	20
8.4	Material identification number	20
9	Technical data	21
10	Dimensions	22



1 General safety instructions

- The device must be mounted, started up or serviced by fully trained and qualified personnel only; the accepted industry codes and practices are to be observed. Make sure employees or third parties are not exposed to any danger.
- All safety instructions and warnings given in these mounting and operating instructions, particularly those concerning installation, start-up, and maintenance, must be strictly observed.
- According to these mounting and operating instructions, trained personnel refers to individuals who are able to judge the work they are assigned to and recognize possible dangers due to their specialized training, their knowledge and experience as well as their knowledge of the applicable standards.
- The device complies with the requirements of the European Pressure Equipment Directive 2014/68/EU, Machinery Directive 2006/42/EC, Directive 2016 No. 1105 Pressure Equipment (Safety) Regulations 2016 and Directive 2008 No. 1597 Supply of Machinery (Safety) Regulations 2008. Valves with a CE marking and/or UKCA marking have a declaration of conformity, which includes information about the applied conformity assessment procedure.
- To ensure appropriate use, only use the device in applications where the operating pressure and temperatures do not exceed the specifications used for sizing the device at the ordering stage.
- The manufacturer does not assume any responsibility for damage caused by external forces or any other external factors.
- Any hazards that could be caused in the temperature regulator by the process medium, operating pressure or by moving parts are to be prevented by taking appropriate precautions.
- Proper transport, storage, installation, operation and maintenance are assumed.



Testing according to DIN EN

The Type 2212 Safety Temperature Limiter combined with Types 2111, 2422 and 2119 Valves has been tested by the German technical surveillance association TÜV according to DIN EN 14597. The registration number is available on request.

2 Process medium and scope of application

Safety temperature limitation of the energy supply to heat generators or heat exchangers by closing and locking a valve. Additional pressure limitation if equipped with pressure element.

For limit signals from **10 to 170 °C** · Valves **DN 15 to 150** · **PN 16 to 40** · Max. **350 °C**

3 Transportation and storage

The device must be carefully handled, transported and stored. Protect the device against adverse influences, such as dirt, moisture or temperature outside the permissible ambient temperature range.

4 Design and principle of operation

See Fig. 2 on page 7.

The safety temperature limiter (STL) is used to limit the temperature by closing and locking a SAMSON Type 2111, 2422 or 2119 Valve connected to the thermostat.

The safety temperature limiter consists of a connecting element with spring mechanism (8), a thermostat with capillary tube (10) and a temperature bulb sensor with thermowell (9). The connection of an additional thermostat converts the safety temperature limiter (STL) into a temperature regulator with safety temperature limiter (TR/STL).

The temperature of the measured medium creates a pressure in the sensor (9) which is proportional to the measured temperature. This pressure is transferred to an operating bellows through a capillary tube (10) where it is converted into a positioning force and compared to the force of the set point spring. The spring force depends on the temperature limit adjusted at the set point adjuster (11). When the temperature exceeds the adjusted limit value, the spring mechanism in the connecting element (8) is released. This causes a pin (6) to move the plug stem (5) to close and lock the valve. The valve closes when the capillary tube ruptures or the sensor leaks. They can only be reset and put back into operation after the fault has been remedied and the temperature falls below the limit by approx. 10 K.

i Note

The Type 2212 Safety Temperature Limiter requires no maintenance. For example, the moving parts in the connecting element do not need to be lubricated.

5 Installation

See Fig. 2 on page 7.

The safety temperature limiter is always installed in the plant in combination with a valve to form an STL or additionally with a temperature regulator to form a TR/STL. The connecting element with spring mechanism (8) can be connected to the valve either before or after the valve is installed in the pipeline.

On installation, make sure that the temperature does not exceed the max. permissible ambient temperature of 80 °C.

If the safety thermostat is used in combination with Series 42 Differential Pressure and Flow Regulators (see TV-SK 7770 document), a separating piece must be mounted on the operating element of the thermostat to connect the actuator (Types 2424, 2427, 2428 and 2429 with force limiter). See Table 1.

i Note

Before installation, remove the snap ring on the pin of the separating piece.

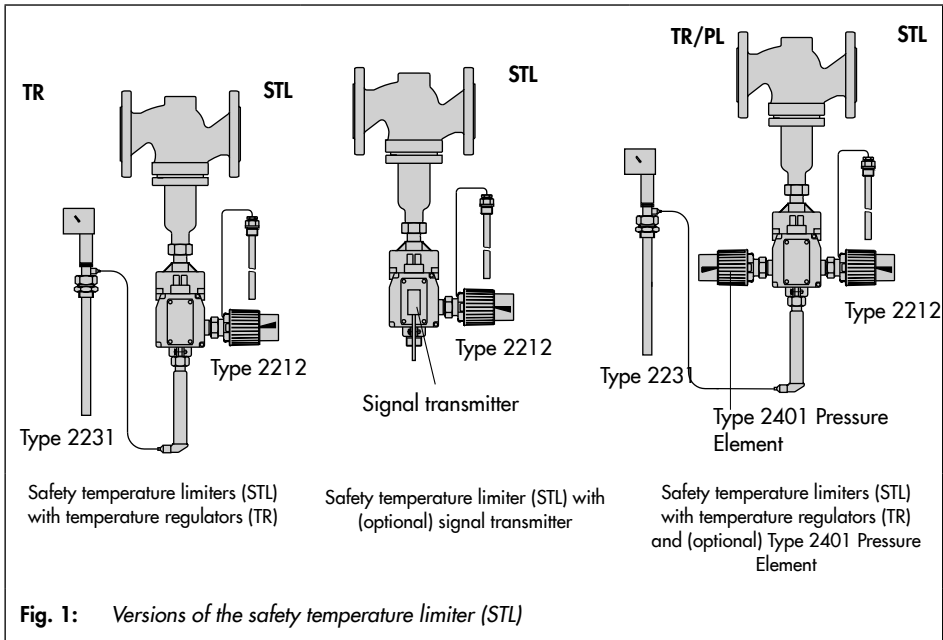

Fig. 1: Versions of the safety temperature limiter (STL)

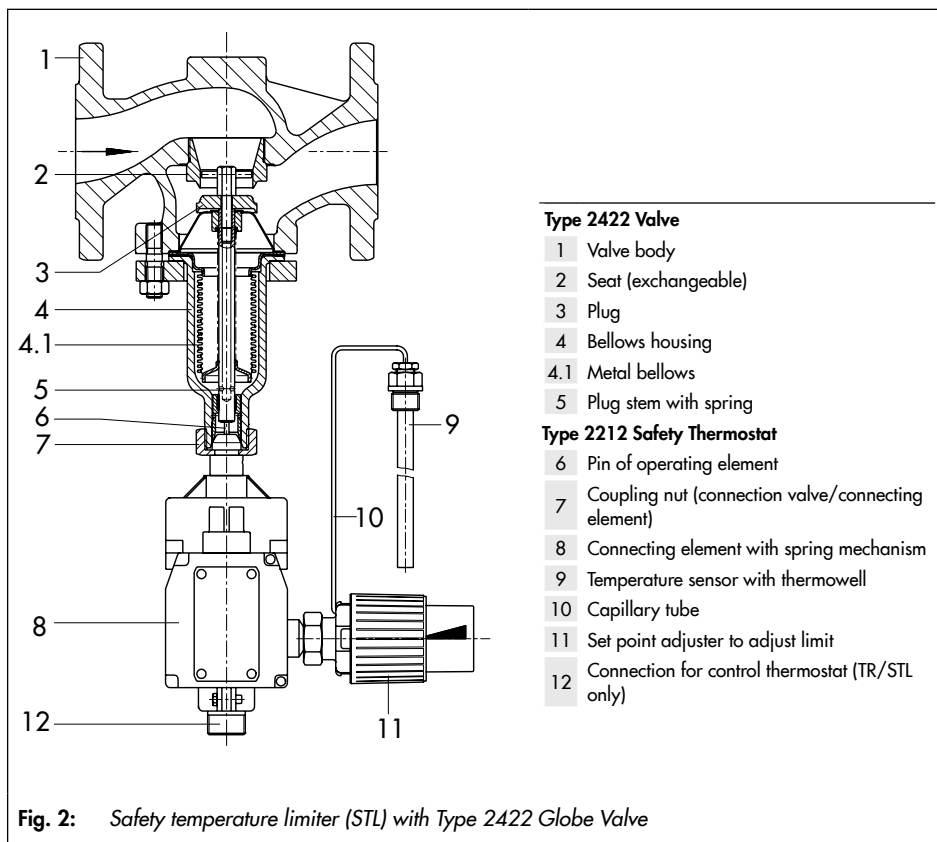

Table 1: Separating pieces

Version with separating piece	Order no.
Brass · For water	1190-9948
Stainless steel · For water	1590-7703
Stainless steel · For oil	1590-7704

5.1 Installing the valve

Choose a place of installation that allows you to freely access the regulator even after the entire plant has been completed.

Flush the pipeline thoroughly before installing the safety temperature limiter with valve. Install a strainer upstream of the regulator to prevent any sealing parts, weld spatter and other impurities carried along by the process medium impairing the proper functioning of the valve, above all the tight shut-off.

i Note

Install the valve in a horizontal pipeline with the operating element connection suspended downward.

- Install the valve free of stress and with the least amount of vibrations as possible. If necessary, support the pipelines near the connections.

5.2 Strainers

Install a strainer (e.g. SAMSON Type 2 NI) upstream of the valve to prevent any sealing parts, weld spatter and other impurities carried along by the process medium impairing the proper functioning of the valve, above all the tight shut-off.

The filter element must be installed to hang downward. Remember to leave enough space to remove the filter element.

5.3 Additional mounting instructions

We recommend installing a hand-operated shut-off valve upstream of the strainer and downstream of the regulator to be able to shut down the plant for cleaning and maintenance and when the plant is not used for longer periods of time.

To check the adjusted limit, we recommend installing a thermometer immersed in the medium to be controlled near the sensor.

5.4 Temperature sensor

i Note

Do not separate the thermostat and operating element (with capillary tube and temperature sensor).

The temperature sensor with a thermowell may be installed in any position. However, make sure its entire length is immersed in the process medium to be controlled. It must be installed in a location where overheating or considerable idling times cannot occur.

! NOTICE

Galvanic corrosion due to incorrectly selected materials of the mounting parts.

On installing the sensor or thermowell, only combine the same kind of materials (e.g. stainless steel with stainless steel or copper together with other copper materials).

Weld a welding socket with G 1 female thread at the place of installation. Seal the

thermowell into the welding socket. Insert the sensor and tighten it with the clamping screw.

i Note

For temperature regulators with safety temperature limiter (TR/STL), install the sensor of the limiter near the sensor of the regulator.

5.4.1 Capillary tube

Carefully run the capillary tube without bending or twisting it. Avoid locations with considerable ambient temperature fluctuations along the entire length of the tube.

i Note

Do not damage or shorten the capillary tube. Roll up any capillary tube that is not used. The smallest permissible bending radius is 50 mm.

5.5 Additional electric unit

The safety temperature limiter can be fitted with an electric signal transmitter.

5.5.1 Electric signal transmitter

The signal transmitter contains a microswitch which generates a signal if the temperature limit is exceeded or if the sensor fails (capillary tube ruptures).

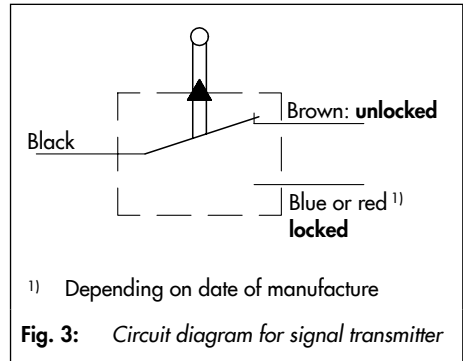

6 Start-up and operation

Fill the plant very slowly with the process medium on start-up.

NOTICE

Malfunction and damage due to adverse weather conditions (temperature, humidity). Do not install the temperature regulator outdoors or in rooms prone to frost. If such a location cannot be avoided, protect the regulator against freezing up if the process medium flowing through the valve can freeze up. Either heat the regulator or remove it from the plant and completely drain the residual medium.

6.1 Limit adjustment

The safety temperature limiter is adjusted to the limit value specified in the order.

Start-up and operation

If no value has been specified, the range from 10 to 95 °C is set to 90 °C, the range from 20 to 120 °C to 110 °C and the range from 40 to 170 °C to 150 °C.

If another temperature limit is to be adjusted, turn the black plastic ring according to the scale (see Table 2).

- Turn clockwise (↻) to reduce the temperature
- Turn counterclockwise (↺) to increase the temperature

Table 2: Limit adjustment

Scale marking	Limit range			
	10 to 95 °C	20 to 120 °C	40 to 170 °C	
	0	~10 °C	~20 °C	~40 °C
	1	~35 °C	~40 °C	~55 °C
	2	~55 °C	~65 °C	~95 °C
	3	~75 °C	~95 °C	~135 °C
	4	~95 °C	~125 °C	~180 °C
Change of limit range Changes per turn in K	~3.2	~3.9	~5.6	

i Note

Before adjusting the limit value, the safety temperature limiter must be mounted on the valve.

The setting is continuously adjustable. A turn corresponds to approx. 3.2 K, 3.9 K or 5.6 K depending on the limit range (see Table 2).

For precise adjustment, first set the maximum set point by turning the black plastic ring counterclockwise (↺). Immerse the temperature sensor for at least five minutes in a temperature bath heated to the corresponding temperature limit. Afterwards, reduce the set point by slowly turning the black plastic ring clockwise (↻) until the temperature limit is reached and the spring mechanism is triggered.

6.2 Unlocking after a fault

The valve is locked when the pin has moved to the top of the inspection window of the connecting element (see Fig. 4).

Unlock the valve at the lever (Fig. 4) after the fault has been remedied. Position the lever and move it upward.

i Note

The valve can only be unlocked after the temperature limit has fallen below the adjusted limit value by at least 10 K.

i Note

If the hydraulic system of the Type 2212 is defective (pressure loss), the STL cannot be unlocked as a result. It must be replaced with a new device.

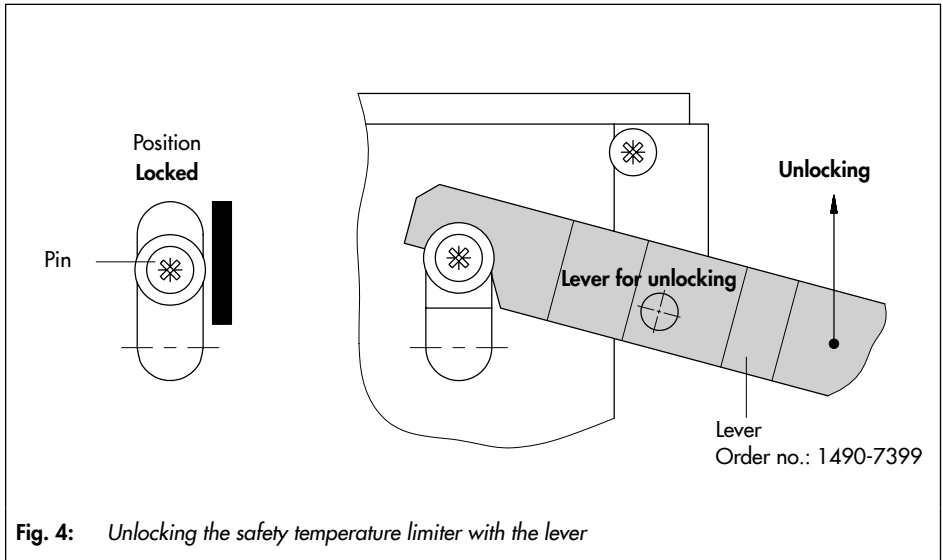

Fig. 4: Unlocking the safety temperature limiter with the lever

6.3 Special version of Type 2401 Pressure Element

Pressure limiters (PL): unlocking after the pressure exceeds the adjusted pressure limit.

Safety pressure limiters: unlocking after the pressure exceeds the adjusted pressure limit and upon pressure failure

6.3.1 Unlocking the Type 2401 Pressure Element

Pressure limiters (PL): unlocking after the pressure falls below the limit by 0.5 bar.

Safety pressure limiters: unlocking only at a pressure of 1 bar or more and after the pressure exceeds the adjusted pressure limit by 0.5 bar

6.4 Servicing

When the connecting element of the safety temperature limiter is defective, the spring mechanism can no longer be compressed.

Contact SAMSON's After-sales Service for support concerning service or repair work or when malfunctions or defects arise.

Start-up and operation

E-mail: aftersalesservice@samson.de

Addresses of SAMSON AG and its subsidiaries

The addresses of SAMSON AG, its subsidiaries, representatives and service facilities worldwide can be found on the SAMSON website (► www.samsongroup.com), in all SAMSON product catalogs or on the back of these Mounting and Operating Instructions.

Observe the following points on installing or removing the regulator from the pipeline:

WARNING

Risk of injury due to process medium escaping possibly under pressure.

Depressurize the relevant section of the pipeline and, if necessary, drain it as well. When used at high temperatures, allow the plant section to cool down to ambient temperature.

6.5 Disposal

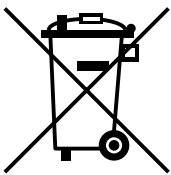

We are registered with the German national register for waste electric equipment (stiftung ear) as a producer of electrical and electronic equipment, WEEE reg. no.: DE 62194439

- Observe local, national and international refuse regulations.
- Do not dispose of components, lubricants and hazardous substances together with your other household waste.

Note

SAMSON can provide you with a recycling passport according to PAS 1049 on request. Simply e-mail us at aftersalesservice@samsongroup.com giving details of your company address.

Tip

On request, SAMSON can appoint a service provider to dismantle and recycle the product.

6.6 Returning devices to SAMSON

Defective devices can be returned to SAMSON for repair.

Proceed as follows to return devices:

1. Exceptions apply concerning some special device models
 - www.samsongroup.com > Service > After-sales Service.
2. Send an e-mail ► retouren@samsongroup.com to register the return shipment including the following information:
 - Type
 - Material number
 - Item numbers of accessories
 - Original order
 - Completed Declaration on Contamination, which can be downloaded from our website at

- ▶ www.samsongroup.com > Service > After-sales Service.

After checking your registration, we will send you a return merchandise authorization (RMA).

3. Attach the RMA (together with the Declaration on Decontamination) to the outside of your shipment so that the documents are clearly visible.
4. Send the shipment to the address given on the RMA.

i Note

Further information on returned devices and how they are handled can be found at

- ▶ www.samsongroup.com > Service > After-sales Service.
-

7 Certificates

The EU and UKCA declarations of conformity are included on the next pages.

7.1 Information on the UK sales region

The following information corresponds to the Pressure Equipment (Safety) Regulations 2016, STATUTORY INSTRUMENTS, 2016 No. 1105 (UKCA marking). It does not apply to Northern Ireland.

Importer

SAMSON Controls Ltd
Perrywood Business Park
Honeycrock Lane
Redhill, Surrey RH1 5JQ

Phone: +44 1737 766391

E-mail: sales-uk@samsongroup.com

Website: uk.samsongroup.com

EU DECLARATION OF CONFORMITY TRANSLATION



Module D, No. / N° CE-0062-PED-D-SAM 001-22-DEU

For the following products, SAMSON hereby declares under its sole responsibility:

Safety Temperature Limiters STL 2212

combined with valves

2111, 2114, 2118, 2119, 2421, 2422, 2423, 2423E, 2710 (2803, 2811, 2814, 2823)

the conformity with the following requirement.

Directive of the European Parliament and of the Council on the harmonization of the laws of the Member States relating of the making available on the market of pressure equipment. 2014/68/EU of 15 May 2014

EC Type Examination Certificate	Module B	Certificate no. 01 202 931-B-15-0031
Conformity assessment procedure applied	Module D	Certificate no. CE-0062-PED-D-SAM-001-22-DEU

The design is based on the procedures specified in the following standards
DIN EN 12516-2, DIN EN 12516-3 or ASME B16.1, ASME B16.24, ASME B16.34, ASME B16.42

The manufacturer's quality management system is monitored by the following notified body:

Bureau Veritas Services SAS, 8 Cours du Triangle, 92800 PUTEAUX – LA DEFENSE, France
Manufacturer: SAMSON AG, Weismüllerstraße 3, 60314 Frankfurt am Main, Germany

Frankfurt am Main, 01. December 2022

Norbert Tollas
Senior Vice President
Global Operations

Peter Scheermesser
Director
Product Maintenance & Engineered Products

Revision 05

Classification: Public · SAMSON AKTIENGESELLSCHAFT · Weismuellerstrasse 3 · 60314 Frankfurt am Main, Germany Seite 1 von 1

SMART IN FLOW CONTROL



SAMSON

**EU Konformitätserklärung / EU Declaration of Conformity /
Déclaration UE de conformité**

Die alleinige Verantwortung für die Ausstellung dieser Konformitätserklärung trägt der Hersteller/
This declaration of conformity is issued under the sole responsibility of the manufacturer/
La présente déclaration de conformité est établie sous la seule responsabilité du fabricant.
Für das folgende Produkt / For the following product / Nous certifions que le produit

**Sicherheitstemperaturbegrenzer / Safety Temperatur Limiter /
Limiteur de température de sécurité
Typ/Type/Type 2212**

wird die Konformität mit den einschlägigen Harmonisierungsrechtsvorschriften der Union bestätigt/
the conformity with the relevant Union harmonisation legislation is declared with/
est conforme à la législation d'harmonisation de l'Union applicable selon les normes:

EMC 2014/30/EU	EN 61000-6-2:2005, EN 61000-6-3:2007 +A1:2011, EN 61326-1:2013
LVD 2014/35/EU	EN 60730-1:2016, EN 61010-1:2010
RoHS 2011/65/EU	EN 50581:2012

Hersteller / Manufacturer / Fabricant:

SAMSON AKTIENGESELLSCHAFT
Weismüllerstraße 3
D-60314 Frankfurt am Main
Deutschland/Germany/Allemagne

Frankfurt / Francfort, 2017-07-29

Im Namen des Herstellers/ On behalf of the Manufacturer/ Au nom du fabricant.

i.V. Gert Nehler

Gert Nehler
Zentralabteilungsleiter/Head of Department/Chef du département
Entwicklung Automation und Integrationstechnologien/
Development Automation and Integration Technologies

i.v. H. Zager

Hanno Zager
Leiter Qualitätssicherung/Head of Quality Management/
Responsable de l'assurance de la qualité

ca_2712-0_de_en_1_in_07.pdf

DECLARATION OF INCORPORATION TRANSLATION



Declaration of Incorporation in Compliance with Machinery Directive 2006/42/EC

For the following product:

Type 2212 Safety Thermostat

We certify that the Type 2212 Safety Thermostat is partly completed machinery as defined in the Machinery Directive 2006/42/EC and that the safety requirements stipulated in Annex I, 1.1.2, 1.1.3, 1.1.5, 1.3.2, 1.3.4 and 1.3.7 are observed. The relevant technical documentation described in Annex VII, part B has been compiled.

Products we supply must not be put into service until the final machinery into which it is to be incorporated has been declared in conformity with the provisions of the Machinery Directive 2006/42/EC.

Operators are obliged to install the products observing the accepted industry codes and practices (good engineering practice) as well as the mounting and operating instructions. Operators must take appropriate precautions to prevent hazards that could be caused by the process medium and operating pressure in the valve as well as by the signal pressure and moving parts.

The permissible limits of application and mounting instructions for the products are specified in the associated mounting and operating instructions; the documents are available in electronic form on the Internet at www.samsongroup.com.

For product descriptions refer to:

- Safety Temperature Limiters (STL) with Type 2212 Safety Thermostat:
Mounting and Operating Instructions EB 2046

Referenced technical standards and/or specifications:

- VCI, VDMA, VGB: "Leitfaden Maschinenrichtlinie (2006/42/EG) – Bedeutung für Armaturen, Mai 2018" [German only]
- VCI, VDMA, VGB: "Zusatzdokument zum Leitfaden Maschinenrichtlinie (2006/42/EG) – Bedeutung für Armaturen vom Mai 2018" [German only], based on DIN EN ISO 12100:2011-03

Comments:

- See mounting and operating instructions for residual hazards.
- Also observe the referenced documents listed in the mounting and operating instructions.

Persons authorized to compile the technical file:

SAMSON AG, Weismüllerstraße 3, 60314 Frankfurt am Main, Germany
Frankfurt am Main, 10 November 2021

A handwritten signature in black ink, appearing to read "S. Giesen".

Stephan Giesen
Director
Product Management

A handwritten signature in black ink, appearing to read "P. Scheermesser".

Peter Scheermesser
Director
Product Life Cycle Management and ETO
Development for Valves and Actuators

Revision no. 00

Zertifikat Certificate

EG-Baumusterprüfung nach Richtlinie 97/23/EG

EC-Type-Examination
in accordance with Directive 97/23/EC

Zertifikat Nr.:
Certificate no:

01 202 931-B-15-0031

Name und Anschrift des
Herstellers:
Name and address of manufacturer:

Samson AG
Weismüllerstraße 3
60314 Frankfurt a.M.

Hiermit wird bescheinigt, dass das unten genannte EG-Baumuster die Anforderungen der Richtlinie 97/23/EG erfüllt.

It is herewith certified that the EC-Type Example mentioned below meets the requirements of the Directive 97/23/EC.

Geprüft nach Richtlinie 97/23/EG:
Approved according to directive 97/23/EC

EG-Baumusterprüfung (Modul B)
EC Type examination (Module B)

EG-Baumuster-Prüfbericht Nr.:
EC-type-approval-report no.:

T 125 2015 B6 vom 03.12.2015

Typ:
Type:

Typ 2212 mit Stellgliedern / with valves 2111 (2811), 2111 (2710), 2114 (2814), 2118 (2713), 2119 (2803), 2422 (2814), 2423 (2823)

Beschreibung des Baumusters:
Description of the sample:

Stetig wirkender Sicherheitstemperaturbegrenzer ohne Hilfsenergie
Temperature limiter without auxiliary energy for continuous operation

Fertigungsstätte/Lieferer:
Manufacturing plant:

Samson AG
Weismüllerstraße 3
60314 Frankfurt a.M.

Gültig bis Ende:
Valid until end of:

12.2025

Das CE-Zeichen darf erst am Produkt angebracht und die Konformitätserklärung erst ausgestellt werden, wenn ein korrespondierendes Konformitätsbewertungsverfahren der Richtlinie 97/23/EG bezogen auf Produktion/Produkt vollständig erfüllt ist.

CE marking must not be affixed and the Declaration of Conformity not be issued prior to completion of the corresponding conformity assessment procedure according to Directive 97/23/EC.

Köln, 03.12.2015

Dipl.-Ing. Ruff

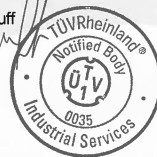

TÜV Rheinland-Zertifizierungsstelle
für Druckgeräte der
TÜV Rheinland Industrie Service GmbH
Benannte Stelle, Kennnummer 0035
Am Grauen Stein, D-51105 Köln

www.tuv.com

 **TÜVRheinland®**
Precisely Right.

UK UK DECLARATION OF CONFORMITY
CA ORIGINAL



**The Pressure Equipment (Safety) Regulations 2016
Module D / N° CE-0062-PED-D-SAM 001-22-DEU**

For the following products, SAMSON hereby declares under its sole responsibility:

Devices	Type	Version
Self-operated Regulators	2212	Safety Temperature Limiter (STL)

The object of the declaration described above is in conformity with the relevant Union harmonization legislation:

Legislation: STATUTORY INSTRUMENTS – 2016 No. 1105 – CONSUMER PROTECTION HEALTH AND SAFETY – The Pressure Equipment (Safety) Regulations 2016	PE(S)R 2016	2022
EU-Type Examination	Module B	Certificate-No.: 01 202 931-B-15-0031 by TÜV Rheinland 0035
Applied conformity assessment procedure for fluids according to Article 4(1)	Module D	Certificate-No.: N°CE-0062-PED-D-SAM 001-22-DEU by Bureau Veritas 0062

The manufacturer's quality management system is monitored by the following approved body:
Bureau Veritas Services SAS, 8 Cours du Triangle, 92800 PUTEAUX – LA DEFENSE (No. 0062)
Designated Standards applied: EN 12516-2, EN 12516-3;
Other technical standards applied: ASME B16.1, ASME B16.24, ASME B16.34, ASME B16.42

Manufacturer:
SAMSON AKTIENGESELLSCHAFT, Weismüllerstraße 3, 60314 Frankfurt am Main, Germany
Frankfurt am Main, 11th November 2022

Norbert Tollas

Norbert Tollas
Senior Vice President
Global Operations

Peter Scheermesser

Peter Scheermesser
Director
Product Maintenance & Engineered Products

Revision 00

Classification: Public · SAMSON AKTIENGESELLSCHAFT · Weismüllerstraße 3 · 60314 Frankfurt am Main, Germany

Page 1 of 1

UK UK DECLARATION OF INCORPORATION
CA ORIGINAL



Declaration of Incorporation of Partly Completed Machinery

in accordance with Schedule 2 Part 2 Annex II, section 1.B. of the Directive 2008 No. 1597 Supply of Machinery (Safety) Regulations 2008

For the following product:

Type 2212 Safety Thermostat

We certify that the Type 2212 Safety Thermostat is partly completed machinery as defined in the in Directive 2008 No. 1597 Supply of Machinery (Safety) Regulations 2008 and that the safety requirements stipulated in Annex I, 1.1.2, 1.1.3, 1.1.5, 1.3.2, 1.3.4 and 1.3.7 are observed. The relevant technical documentation described in Annex VII, (Part 7 of Schedule 2) part B has been compiled.

Products we supply must not be put into service until the final machinery into which it is to be incorporated has been declared in conformity with the provisions of the Directive 2008 No. 1597 Supply of Machinery (Safety) Regulations 2008.

Operators are obliged to install the products observing the accepted industry codes and practices (good engineering practice) as well as the mounting and operating instructions. Operators must take appropriate precautions to prevent hazards that could be caused by the process medium and operating pressure in the valve as well as by the signal pressure and moving parts.

The permissible limits of application and mounting instructions for the products are specified in the associated mounting and operating instructions; the documents are available in electronic form on the Internet at www.samsongroup.com.

For product descriptions refer to:

- Safety Temperature Limiters (STL) with Type 2212 Safety Thermostat:
Mounting and Operating Instructions EB 2046

Referenced technical standards and/or specifications:

- VCI, VDMA, VGB: "Leitfaden Maschinenrichtlinie (2006/42/EG) – Bedeutung für Armaturen, Mai 2018" [German only]
- VCI, VDMA, VGB: "Zusatzdokument zum Leitfaden Maschinenrichtlinie (2006/42/EG) – Bedeutung für Armaturen vom Mai 2018" [German only], based on DIN EN ISO 12100:2011-03

Comments:

- See mounting and operating instructions for residual hazards.
- Also observe the referenced documents listed in the mounting and operating instructions.

Persons authorized to compile the technical file:

SAMSON AG, Weismüllerstraße 3, 60314 Frankfurt am Main, Germany
Frankfurt am Main, 27 April 2022

Stephan Giesen
Director
Product Management

Peter Scheermesser
Director
Product Maintenance & Engineered Products

Revision 00

8 Markings on the device

The nameplate shown was up to date at the time of publication of this document. The nameplate on the device may differ from the one shown.

8.1 Nameplate of Type 2212 Safety Thermostat

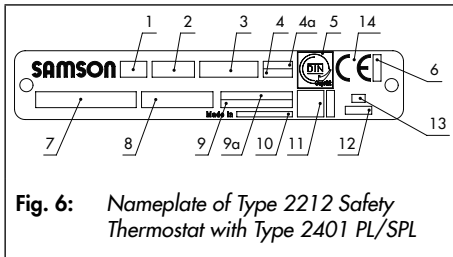
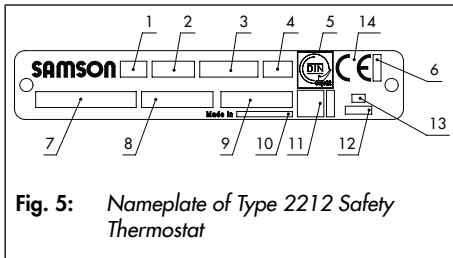

1	Type	8	TÜV or DIN number
2	Material number/ configuration ID	9	Limit range in °C
3	Serial number	9a	Limit range in bar
4	Limit in °C	10	Country of origin
4a	Limit value in bar	11	UKCA, if applicable
5	DIN tested	12	Year of manufacture
6	ID of the certification body	13	Month of manufacture
7	-	14	CE marking

8.2 Valve nameplate

See associated valve documentation.

8.3 Location of the nameplate

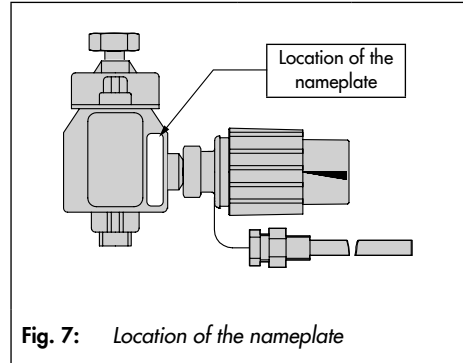



8.4 Material identification number

Specifying the material number, you can contact SAMSON to find out which material is used. For more details on the nameplate, see Chapter 8.1.

9 Technical data

Table 3: *Technical data*

Type 2212 Safety Thermostat for STL	Size 50 ¹⁾	Size 150 ¹⁾
Adjustable limit range	10 to 95 °C · 20 to 120 °C · 40 to 170 °C	
Max. perm. ambient temperature	+80 °C	
Min. permissible sensor temperature ²⁾ at 0 °C ambient temperature	Smallest adjustable temperature limit of the selected limit range	
Min. permissible temperature of the STL including sensor when the plant is shut down ²⁾ with Limit range 10 to 95 °C Limit range 20 to 120 °C Limit range 40 to 170 °C	-10 °C 0 °C 10 °C	
Max. permissible temperature at sensor	20 K above the adjusted set point	
Capillary tube length	5 m (10 m as special version) ³⁾	
Pressure rating with G 1/2 thermowell	PN 40	
Electric signal transmitter Max. load at 120/230 V (AC)	10 A with resistive load	
Class of protection	IP 67	
Conformity	 	

¹⁾ Size 50: Type 2212 for valve DN 15 to 50 | Size 150: Type 2212 for valve DN 65 to 150

²⁾ The STL is locked when the temperature falls below the specified temperature.

³⁾ Not tested according to DIN EN

10 Dimensions

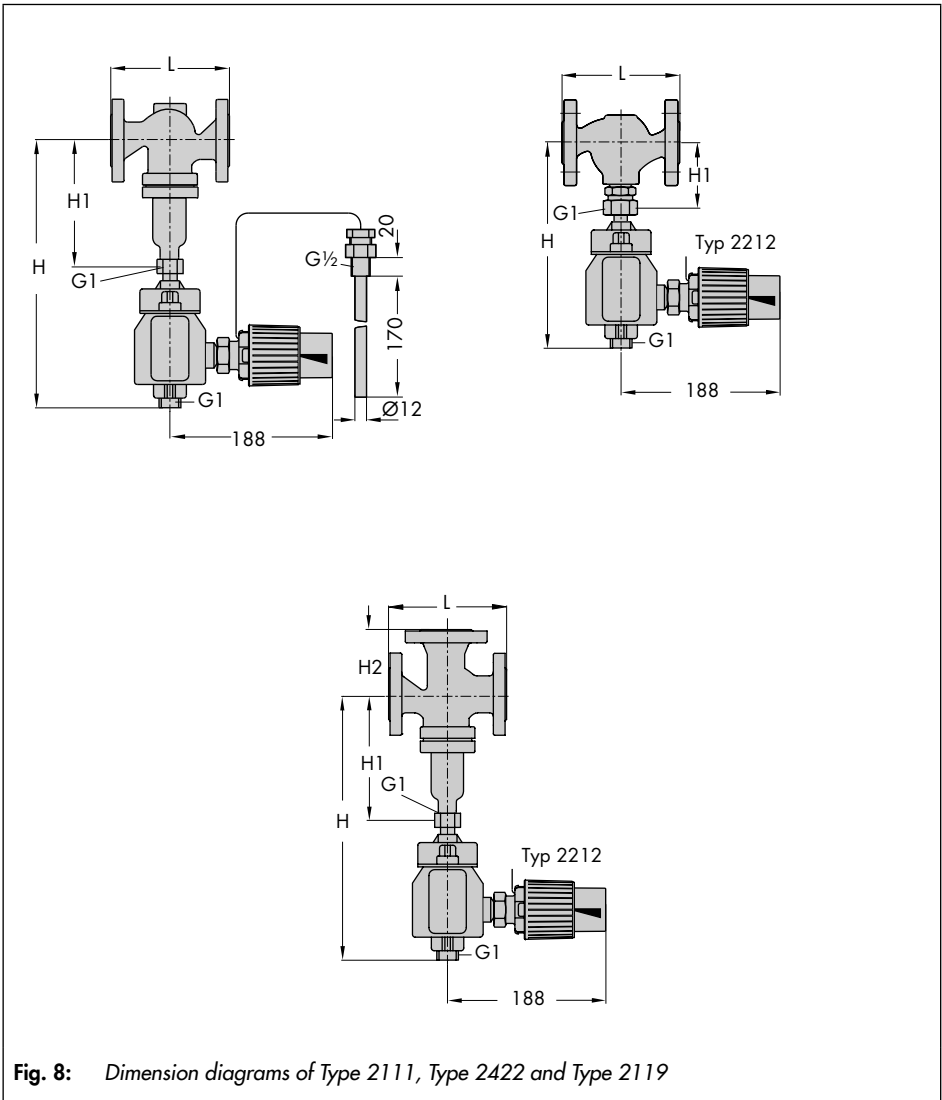

Fig. 8: Dimension diagrams of Type 2111, Type 2422 and Type 2119

Table 4: Dimensions in mm and weights in kg

Nominal size DN	15	20	25	32	40	50	15	20	25	65	80	100	125	150
Valve	Type 2422			Type 2111/ (Type 2422)			Type 2111			Type 2422¹⁾				
Length L	130	150	160	180	200	230	130	150	160	290	310	350	400	480
H1 Without Extension With	225			225 ³⁾ /152 ⁴⁾ /(225)			225 ³⁾ /82 ⁴⁾			300	355	460	590	
	365			365 ³⁾ /- ⁴⁾ /(365)			365 ³⁾ /- ⁴⁾			440	495	600	730	
Weight (PN 16 body) ²⁾ , approx. kg	5	5.5	6.5	13	13.5	16	4	4.5	5.5	27	32	40	70	113
Valve	Type 2119													
Length L	130	150	160	180	200	230	-			290	310	350	400	480
H2	70	80	85	100	105	120	-			130	140	150	200	210
H1 Without Extension With	235			88/245			-			320	355	395	500	
	375			-/385			-			460	495	535	640	
Weight (PN 16 body) ²⁾ , approx. kg	6	7	8.5	12.5/ 15	14.5/ 17	17/ 19	-			32	50	71	On request	
Overall height H	STL			H = H1 + 255										
	TR/STL			H = H1 + 545										
Type 2212 Safety Thermostat														
Weight	Approx. 3.5 kg													

1) Details on STL and TR/STL with Type 2422 Valve in DN 200 and 250 available on request.

2) +15 % for PN 25/40

3) Type 2111, valve material 1.0619 and stainless steel

4) Type 2111, valve material EN-GJS-400-18-LT and EN-JL-1040



SAMSON AKTIENGESELLSCHAFT
Weismüllerstraße 3 · 60314 Frankfurt am Main, Germany
Phone: +49 69 4009-0 · Fax: +49 69 4009-1507
samson@samsongroup.com · www.samsongroup.com