

INFORMATION SHEET



T 2010 EN

Type 1 to Type 9 Temperature Regulators

Self-operated Temperature Regulators

PN 16 to 40 · Class 125 to 300

DN 15 to 150 · NPS ½ to 6

G ½ to G 1 · ½ NPT to 1 NPT

-10 to 350 °C · 15 to 660 °F

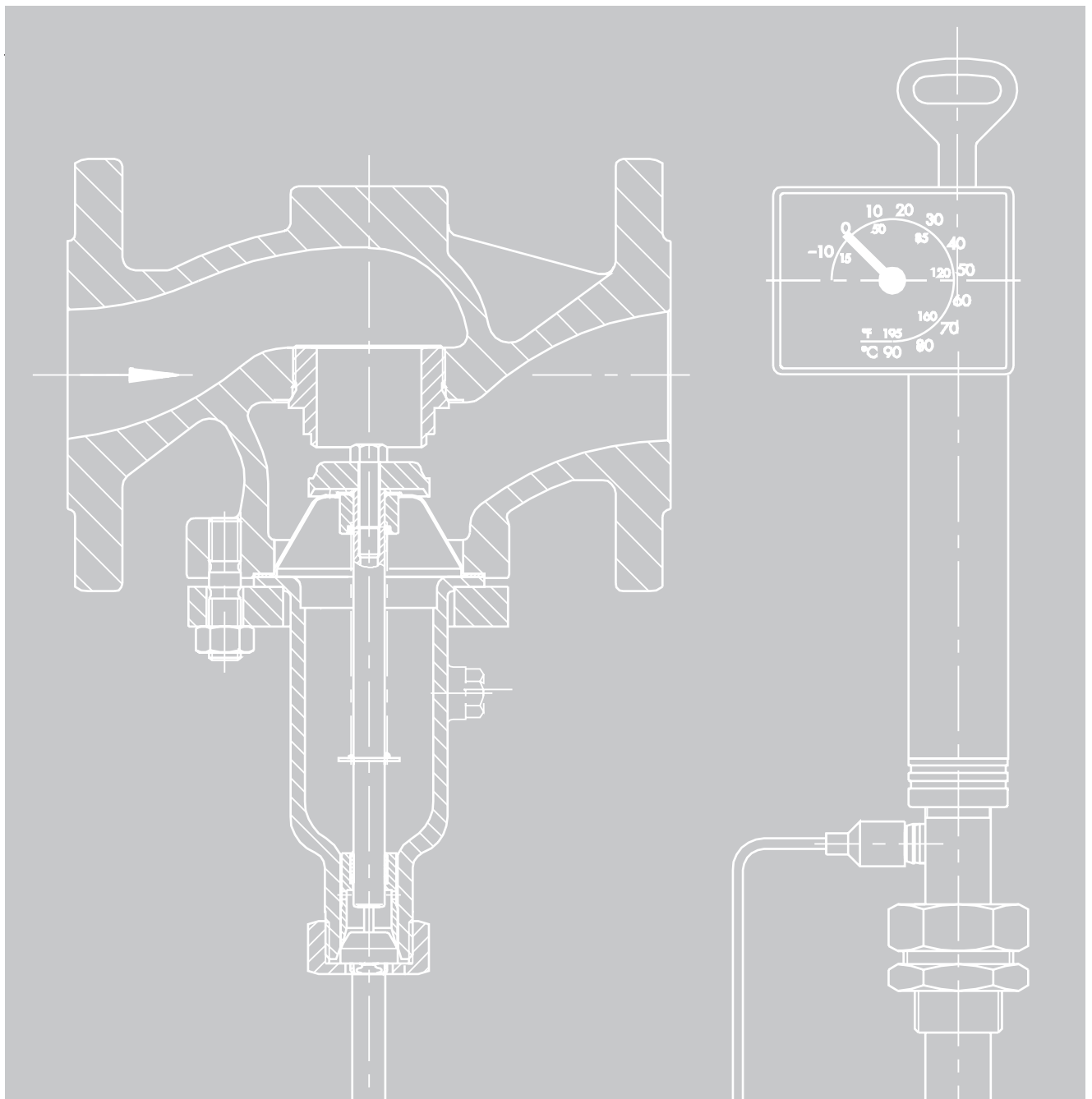

Self-operated temperature regulators

DIN versions

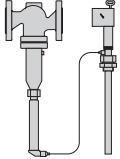
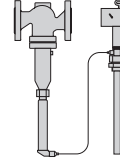
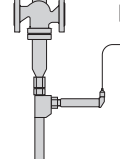
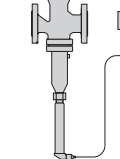
Valves	Can be used for	Steam	•	•		
		Water and other liquids	•	•	•	•
		Air and non-flammable gases	•	•	•	
		Heating	•	•		
		Cooling			•	
		Mixing/diverting				•
	Globe valve		•	•	•	
	Three-way valve					•
	Balanced			•	•	• ⁴⁾
	Unbalanced		•			
	Conne- ction	Flanges	•	•	•	•
		Female thread				
	Valve size		DN 15 to 50	DN 15 to 150	DN 15 to 150	DN 15 to 150
	Connection size					
Pressure rating		PN 16 to 40	PN 16 to 40	PN 16 to 40	PN 16 to 40	
Perm. temperature	Max.	350 °C ¹⁾	350 °C	220 °C	350 °C ⁴⁾	
Body material	Cast iron	• ⁵⁾	•	•	•	
	Spheroidal graphite iron	•	•	•	•	
	Cast steel	•	•	•	•	
	Stainless steel	•	•	•	•	
Control thermostats	Type 2231 and Type 2232	•	•	•	•	
	Type 2234	•	•	•	•	
	Adjustable set point	-10 to +250 °C				
	Double adapter possible	•	•		•	
Safety thermostats	Type 2212 (STL)	For safety temperature limiter	•	•	•	
		Adjustment range of limit value	10 to 95 °C · 20 to 120 °C · 30 to 170 °C			
	Type 2213 (STM)	For safety temperature monitor	•	•	•	
		Adjustment range of limit value	-10 to 90 °C · 20 to 120 °C			
Type ...		1	4	4u	9	
Details in Data Sheet ...		▶ T 2111	▶ T 2121	▶ T 2123 ³⁾	▶ T 2133 ³⁾	
						

¹⁾ Only with extension piece ²⁾ DN 15 to 25: EN-GJS-400-18-LT only ³⁾ ANSI version on request ⁴⁾ DN 15 to 25: unbalanced ⁵⁾ DN 40 to 50 only

Control thermostats

Type 2231 · Set point adjustment at the sensor · Set points from -10 to +150 °C (15 to 300 °F) · Suitable for liquids and steam · Installation in pipelines, vessels, heating or cooling systems

Type 2232 · Separate set point adjustment · Set points from -10 to +250 °C (15 to 480 °F) · Application same as Type 2231

Type 2234 · Separate set point adjustment · Set points from -10 to +250 °C (15 to 480 °F) · Suitable for liquids, air and gases · Installation in air ducts, vessels, pipelines, heating or cooling systems
Liquid regulation with quick response times

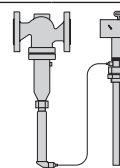

Type 2231

Fig. 1: Control thermostats with set point adjustment at the sensor

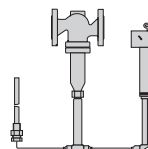

Type 2232

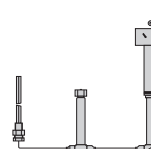

Type 2234

Fig. 2: Control thermostats with separate set point adjustment

Self-operated temperature regulators | ANSI versions

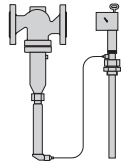
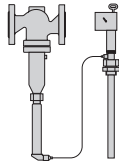
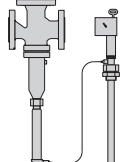
Valves	Can be used for	Steam	•	•	•
		Water and other liquids	•	•	•
		Air and non-flammable gases	•	•	•
		Heating	•	•	
		Cooling			
		Mixing/diverting			•
	Globe valve		•		
	Three-way valve			•	
	Balanced		•	•	
	Unbalanced	•			
	Connection	Flanges	•	•	•
		Female thread			
	Valve size		NPS ½ to 4	NPS ½ to 6	NPS ½ to 6
	Connection size				
Pressure rating		Class 150 and 300	Class 125 and 300	Class 150 and 300	
Perm. temperature	Max.	660 °F	660 °F	660 °F	
Body material	Cast iron		•		
	Cast steel	•	•	•	
	Stainless steel	•	•	•	
Control thermostats	Type 2231 and Type 2232	•	•	•	
	Type 2234	•	•	•	
	Adjustable set point	15 to 480 °F			
	Double adapter possible	•	•	•	
Safety thermostats	Type 2212 For safety temperature limiter (STL)	•	•	•	
	Adjustment range of limit value	50 to 205 °F · 70 to 250 °F · 85 to 340 °F			
Safety thermostats	Type 2213 For safety temperature monitor (STM)	•	•	•	
	Adjustment range of limit value	15 to 195 °F · 70 to 250 °F			
Type ...		1	4	9	
Details in Data Sheet ...		▶ T 2115	▶ T 2025	▶ T 2134	
					

Typetested safety thermostats

The following typetested devices are available for control, limitation, safety monitoring and safety limitation of the energy supplied to heat generators or heat exchangers, which must be equipped with type-tested devices:

- Temperature regulator (TR)
- Safety temperature monitor (STM)
- Safety temperature limiter (STL) and
- Combined regulators

Details can be found in the Information Sheet ▶ T 2040 and Data Sheets ▶ T 2043 and ▶ T 2046.

Fig. 3: Safety thermostats

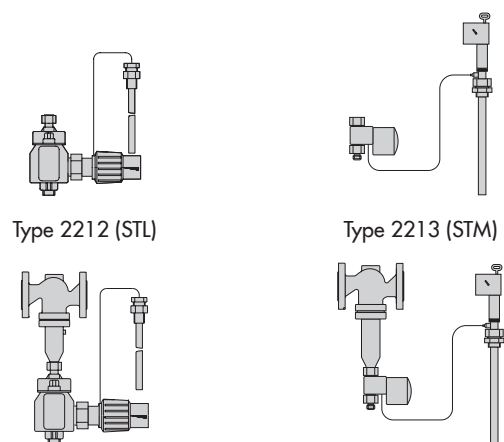

Type 1/2212 · Type 4/2212

Type 1/2213 · Type 4/2213

Pressure-temperature diagrams

The pressures specified in the corresponding data sheets are maximum values which are limited by the pressure-temperature diagram.

For DIN materials, the diagrams were created based on DIN EN 12516-1. For materials in accordance with US standards, these were created in compliance with ASME B16.1 and ASME B16.34.

Pressure-temperature diagram (DIN)

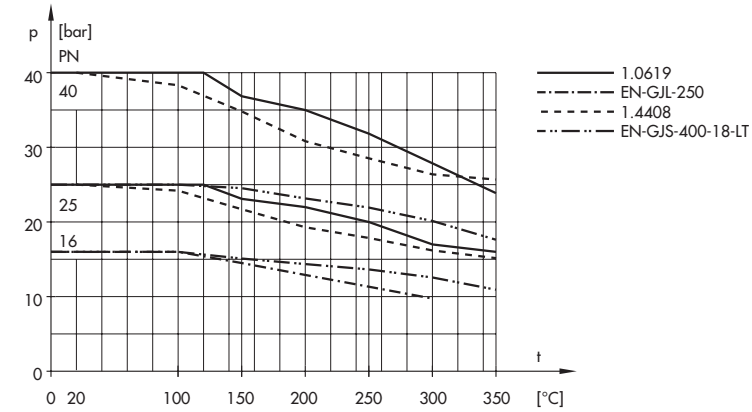

Pressure-temperature diagram (ANSI)

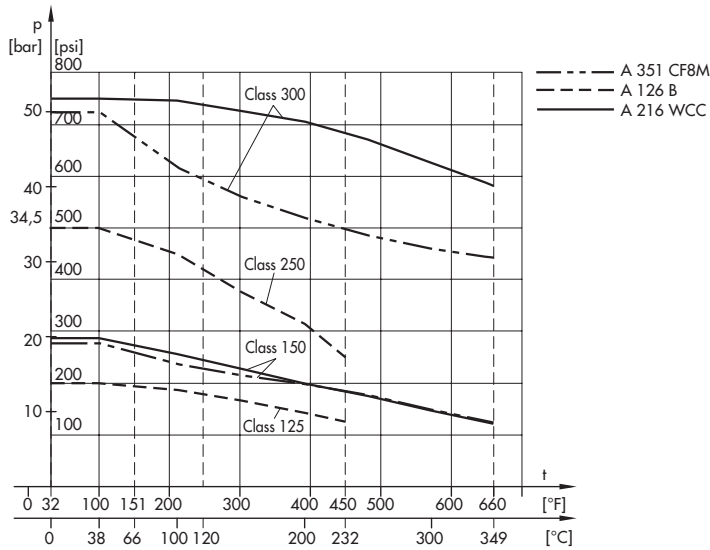

Fig. 4: Pressure-temperature diagrams (DIN/ANSI)

Conversion factors

K_{VS} and C_V coefficient

The exact calculation is performed according to IEC 60534, parts 2-1 and 2-2. The ISA-S75.01-1-1985 standard and VDI/VDE directive 2173 are also used. The calculation of the K_V coefficient according to this directive is sufficiently accurate in most cases. The equations are also listed in the Application Notes AB 04.

$$K_{VS} = 0.86 \times C_V \quad K_{VS} \quad [\text{m}^3/\text{h}]$$

$$C_V = 1.17 \times K_{VS} \quad C_V \quad [\text{US gallon}/\text{min}]$$

Pressure

$$1 \text{ pound}/\text{square inch} [\text{lbs}/\text{in}^2 = \text{psi}] = 0.06895 \text{ bar}$$

$$1 \text{ bar} = 14.5 \text{ psi}$$

Area

$$1 \text{ square inch} [\text{sq.in}; \text{in}^2] = 6.452 \text{ cm}^2$$

$$1 \text{ cm}^2 = 0.155 \text{ in}^2$$

Mass

$$1 \text{ pound} [\text{lb}] = 0.4536 \text{ kg}$$

$$1 \text{ kg} = 2.2046 \text{ lb}$$

Mass flow

$$1 \text{ pound per second} [\text{lb}/\text{s}] = 0.4536 \text{ kg}/\text{s}$$

$$1 \text{ kg}/\text{s} = 2.2046 \text{ lb}/\text{s}$$

Flow rate

$$1 \text{ US gallon per min} [\text{US gallon}/\text{min}] = 0.227 \text{ m}^3/\text{h}$$

$$1 \text{ m}^3/\text{h} = 4.4 \text{ US gallon}/\text{min}$$

Temperature

$$^\circ\text{F} = \frac{9}{5} ^\circ\text{C} + 32$$

$$^\circ\text{C} = \frac{5}{9} (^\circ\text{F} - 32)$$

Principle of operation

Self-operated temperature regulators are control devices whose measuring units draw their energy from the process medium which creates sufficient force to move the final control element (plug with plug stem).

The temperature regulators shown in the schematic diagrams (Fig. 5, Fig. 6 and Fig. 7) operate according to the liquid expansion principle.

They consist of a valve and a control thermostat.

The control thermostat comprises a temperature sensor (11), set point adjuster (13), capillary tube (10) and a hydraulic actuator termed the operating element (7). The sensor is filled with an expansion liquid, which acts over the positioning bellows (9) and the positioning pin (8) upon the valve plug (3) attached to the plug stem (6). The temperature-dependent change in volume of the liquid contained in the sensor and the displacement of the piston (12) located in the set point adjuster cause the bellows and the plug to move.

The hydraulic actuator and the valve, which does not contain a packing, ensure high operating reliability of the regulators. Since the regulators operate on the liquid expansion principle, the temperature sensor and the control thermostat can be adapted to different operating conditions. Therefore, the easy-to-install version (Fig. 5 and Fig. 6) and the version (Fig. 7) are used in most cases for temperatures exceeding 150 °C (300 °F) and in applications where separate installation of the sensor and the set point adjuster is appropriate. The selection of a Type 2231, 2232 or 2234 Temperature Sensor depends on the medium, required time constant and installation situation.

The regulators are proportional regulators controlled by the process medium. Each deviation from the adjusted set point is assigned a certain valve plug position. The control accuracy and stability of the control process depend on the disturbances occurring in the loop (for example, changes in upstream pressure and flow rate). The regulators are designed in such a way that the effect of these disturbances is relatively small. The force acting on the valve plug depending on, for example either the upstream or differential pressure can be eliminated by balancing the plug correspondingly. In unbalanced versions (Fig. 5), the disturbance effect is a force resulting from the cross-section of the seat and the differential pressure. The valves shown in Fig. 6 and Fig. 7 have a balancing bellows. The pressure upstream of the plug (p_1) is transferred through a hole in the plug stem and acts on the outside of the balancing bellows, whereas the pressure downstream of the plug (p_2) acts on the inside of the bellows. As a result, the forces acting on the valve plug are balanced out. The fully balanced valves allow the self-operated regulators to be used for nominal sizes up to DN 150 (valves up to NPS 6 on request).

Legend for Fig. 5 to Fig. 7

Valve

1	Valve body	5	Balancing bellows
2	Seat	6	Plug stem
3	Plug	6.1	Plug stem with hole for pressure balancing
4	Bellows housing		

Control thermostat

7	Operating element	11	Temperature sensor
8	Positioning pin	12	Piston
9	Operating bellows	13	Set point adjustment
10	Capillary tube	14	Set point dial

Functional diagram and temperature regulator versions (schematic diagrams)

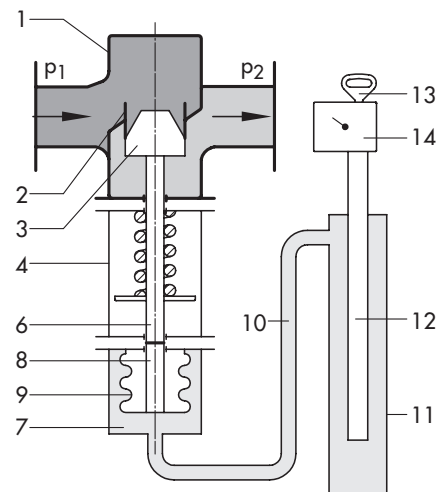

Fig. 5: Temperature regulator with unbalanced valve and compact control thermostat

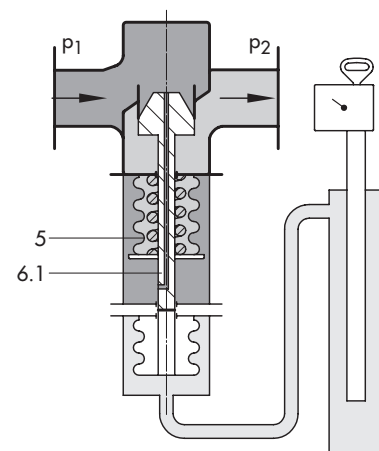

Fig. 6: Temperature regulator with balanced valve and compact control thermostat

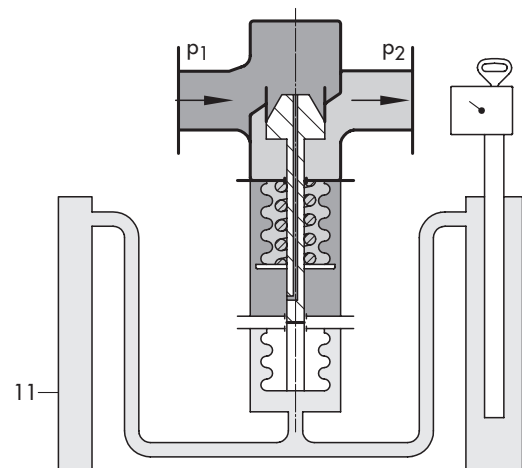

Fig. 7: Temperature regulator with balanced valve and compact control thermostat with separate set point adjustment

Type 1 to Type 9 Temperature Regulators

The temperature regulators consist of a (globe or three-way) valve, a Type 2231, 2232 or 2234 Control Thermostat with temperature sensor, set point adjuster, capillary tube and operating element.

Special features

- Low-maintenance proportional regulators requiring no auxiliary energy
- Globe or three-way valves suitable for liquids, gases and vapors, especially for heat transfer media, such as water, oil and steam or for coolants, such as cooling brine or cooling water
- Valve body optionally made of cast iron, spheroidal graphite iron (DIN version only), cast steel or cast stainless steel
- DIN and ANSI versions

Versions with globe valve

- Regulators for plants to be heated

Type 1 Temperature Regulator · Flanges

With unbalanced single-seated Type 2111 Globe Valve · Body made of either cast iron, spheroidal graphite iron, cast steel or cast stainless steel · The valve closes as the temperature rises
Type 2231 to Type 2234 Control Thermostat

Technical data	Data Sheets ▶ T 2111 · ▶ T 2115
Set points	-10 to +250 °C · 15 to 480 °F
Valve size	DN 15 to 50 · NPS ½ to 2
Pressure rating	PN 16 to 40 · Class 150 to 300
Temperatures	Up to 350 °C ¹⁾ · 660 °F

¹⁾ EN-JL1040/A126B: max. permissible temperature 300 °C

Type 4 Temperature Regulator · Flanges

With balanced single-seated Type 2122 Globe Valve · Body made of either cast iron, cast steel, spheroidal graphite iron (DIN version only) or cast stainless steel · The valve closes as the temperature rises · Type 2231 to Type 2234 Control Thermostat

Technical data	Data Sheets ▶ T 2121 · ▶ T 2025
Set points	-10 to +250 °C · 15 to 480 °F
Valve size	DN 15 to 150 · NPS ½ to 6
Pressure rating	PN 16 to 40 · Class 125 to 300
Temperatures	Up to 350 °C · 660 °F

Regulators with three-way valves for max. 350 °C for mixing or diverting service

- Regulators for plants to be heated or cooled

Type 9 Temperature Regulator · Flanges

With balanced Type 2119 Three-way Valve¹⁾ · Body made of either cast iron, cast steel or cast stainless steel · For mixing or diverting liquids · Type 2231 to Type 2234 Control Thermostats

Technical data	Data Sheets ▶ T 2133 · ▶ T 2134
Set points	-10 to +250 °C · 15 to 480 °F
Valve size	DN 15 to 150 · NPS ½ to 6
Pressure rating	PN 16 to 40 · Class 150 and 300
Temperature	Up to 350 °C · Up to 660 °F

¹⁾ DN 15 to 25: unbalanced

Regulators for plants to be cooled

Type 4u Temperature Regulator · Flanges

Same as Type 4, but equipped with a reversing device · The valve opens as the temperature rises

Technical data	Data Sheet ▶ T 2123
----------------	---------------------

See Type 4

Dynamic behavior of control thermostats and safety thermostats

The dynamics of the regulators are mainly determined by the response of the sensor and its characteristic time constant.

The following table lists the response times of SAMSON control thermostats measured in water for Type 1 to Type 9 Temperature Regulators.

Table 1: Dynamic behavior of control thermostats and safety thermostats

Functional principle	Type ... Control or Safety Thermostat	Time constant [s]	
		Without thermowell	With thermowell
Liquid expansion	2231	70	120
	2232	65	110
	2234	15	- ¹⁾
	2213	70	120
Adsorption	2212	- ¹⁾	40

¹⁾ Not permissible

Combined regulators

A double adapter or manual adjuster can be mounted between the valve and the Type 1, Type 4 and Type 9 Regulator to attach a second control thermostat. For more details refer to Data Sheet ▶ T 2036.

Typetested temperature regulators (TR), safety temperature monitors (STM) and safety temperature limiters (STL) and combined regulators (e.g. TR + STM) for DN 15 to 150 (NPS ½ to 6) and limits up to 170 °C (340 °F) are part of the safety equipment used in heat-generating installations. The globe valve can be replaced by a three-way valve in all versions.

Details can be found in the Information Sheet ▶ T 2040 and Data Sheets ▶ T 2043 and ▶ T 2046.

Thermowells and fastening elements

For Type 2231 and Type 2232 Control Thermostats as well as Type 2212 and Type 2213 Safety Thermostats: thermowells with threaded or flanged connection.

For Type 2234 Control Thermostats: flange, clamp and perforated cover for wall mounting.

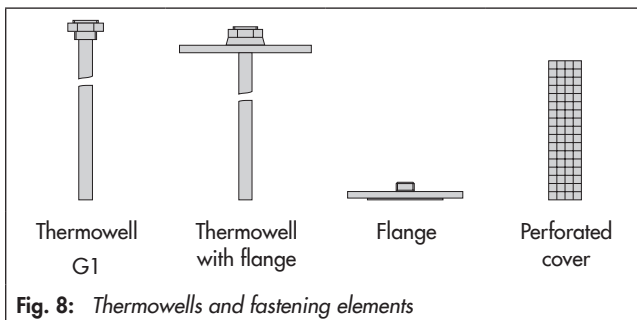

Fig. 8: Thermowells and fastening elements

Accessories

To protect the operating element from inadmissible operating conditions, an extension piece and/or separating piece is installed between the valve and the operating element.

The extension piece is required for valves in DN 15 to 100 (NPS ½ to 4) at temperatures above 220 °C (430 °F).

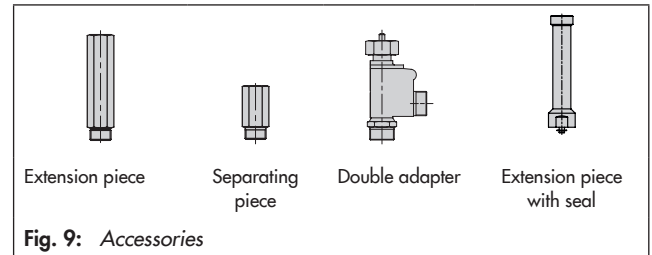

Fig. 9: Accessories

In stainless steel regulators, the separating piece separates the operating element made free of non-ferrous metals from the medium in the valve. In addition, it prevents the medium from escaping on removing the thermostat.

The double adapters are suitable for attaching a second control thermostat. For more details refer to Data Sheet ▶ T 2036.

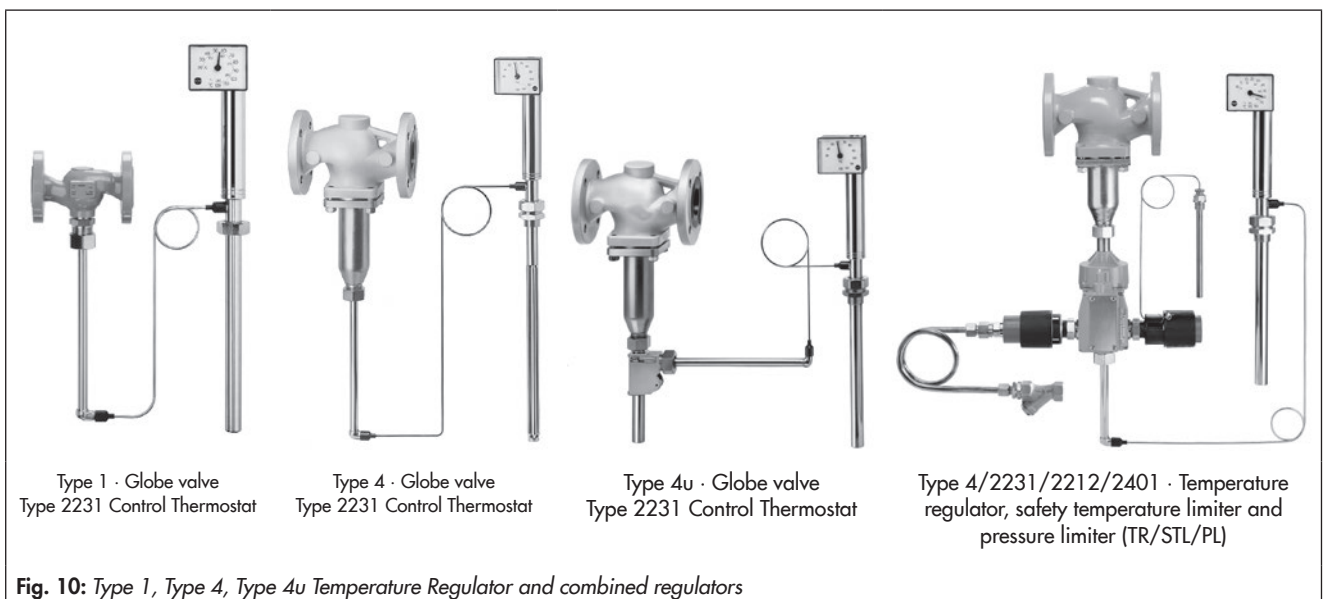

Fig. 10: Type 1, Type 4, Type 4u Temperature Regulator and combined regulators

Sample applications

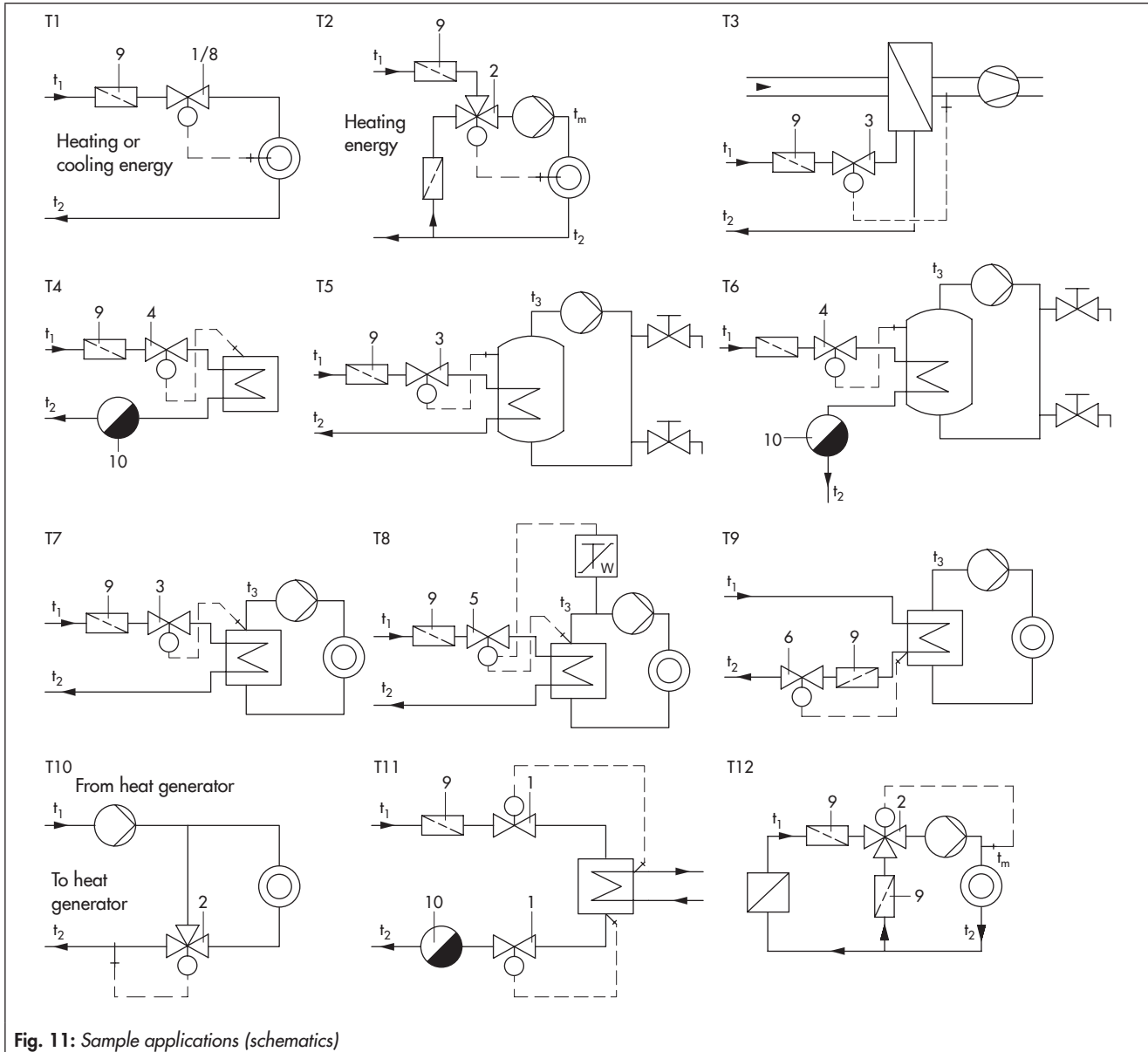

Fig. 11: Sample applications (schematics)

Temperature regulation for different consumers

- T1 Heating or cooling with globe valve
- T2 Heating with three-way valve (mixing valve)
- T3 Regulation of a water-heated air duct
- T4 Regulation of a steam-heated drying cabinet, drying chamber or storeroom

Temperature regulation of boilers, heat generators and heat exchangers

- T5 Regulation of a water-heated boiler
- T6 Regulation of a steam-heated boiler
- T7 Regulation of a heat generator or heat exchanger
- T8 Temperature regulation safeguarded by safety temperature monitor on a heat generator or water-heated heat exchanger

For further application examples of typetested regulators, refer to Information Sheet ► T 2040.

Temperature regulation in district heating systems and cooling installations

- T9 Return flow temperature limitation
- T10 Return flow temperature increase in a boiler system
- T11 Temperature regulation of a condenser
- T12 Regulation of the cooling water circuit of engines or compressors

Legend for typical applications

- 1 Types 1, 4, 4u
- 2 Type 9
- 3 Type 1, 4 with Type 2234 Control Thermostat
- 4 Type 1, 4 with Type 2234 Control Thermostat
- 5 Type 1, 4 with Type 2231 Control Thermostat and Type 2212 Safety Thermostat
- 6 Types 1, 4
- 8 Type 4u
- 9 SAMSON strainer
- 10 Steam traps