

T 2550 EN

Type 2422/2425 Excess Pressure Valve

Self-operated Pressure Regulators · ANSI version



Application

Pressure regulators for set points from **0.75 to 35 psi (0.05 to 2.5 bar)** · Valves in nominal sizes **NPS 6 to 10 (DN 150 to 250)**¹⁾ · Pressure rating **Class 125 to 300** · Suitable for liquids, gases and vapors up to **+660 °F (350 °C)**

The valve **opens** when the **upstream** pressure **rises**.

The excess pressure valves, consisting of a valve and actuator, control the upstream pressure to an adjustable set point. The medium pressure to be kept constant is transmitted through a control line to the diaphragm of the actuator and consequently the valve plug.

Special features

- Low-maintenance, medium-controlled proportional regulators requiring no auxiliary energy
- Wide set point range and convenient set point adjustment using a nut
- Exchangeable set point springs and actuator
- Spring-loaded, single-seated valve with upstream and downstream pressures balanced by a stainless steel bellows or by a balancing diaphragm
- Reduced C_v (K_{vs}) coefficients to adapt the regulator to the operating conditions
- Low-noise plug (standard) Special version with flow divider ST 1 or ST 3 for further noise reduction See Data Sheet ▶ T 8081.

Versions

Type 2422/2425 Excess Pressure Valve in nominal sizes NPS 6 to 10 (DN 150 to 250) consisting of:

Type 2422 Valve balanced by a bellows or a diaphragm with soft-seated plug · Body of cast iron A126 B, cast steel A216 WCC or cast stainless steel A351 CF8M ·

Type 2425 Actuator with EPDM rolling diaphragm

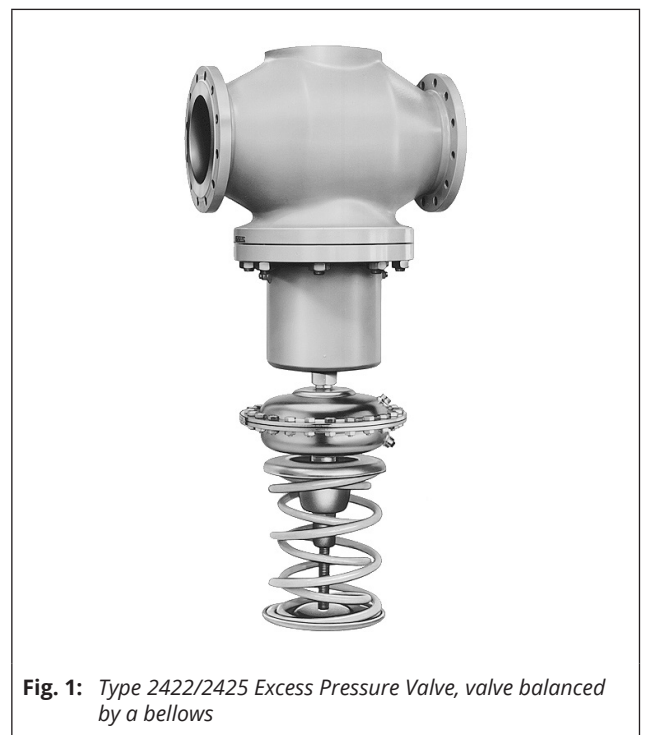

Fig. 1: Type 2422/2425 Excess Pressure Valve, valve balanced by a bellows

Special versions

- With flow divider ST 1 or ST 3 for particularly low-noise operation
- With metal-seated plug
- With FKM rolling diaphragm, e.g. for mineral oils or flammable gases
- With NBR rolling diaphragm for flammable gases
- Version completely in stainless steel for pressure rating Class 150 to 300 · Details on request
- Actuator with two diaphragms
- With metal cover to protect the set point springs

¹⁾ Valves larger than NPS 10 (DN 250) on request

Principle of operation (see Fig. 2)

The medium flows through the valve in the direction indicated by the arrow. The position of the plug (3) determines the flow rate across the area released between plug (3) and valve seat (2). The plug stem (5) with the plug is connected to the actuator stem (11) of the actuator (10).

The upstream pressure p_1 is regulated by the set point springs (7) and the set point adjuster (6). When relieved of pressure, the valve is closed by the force of the set point springs.

The upstream pressure p_1 to be controlled is tapped upstream of the valve and transmitted over the control line to the operating diaphragm (12) where it is converted into a positioning force. This force is used to move the valve plug (3) according to the force of the set point springs. The spring force is adjustable at the set point adjuster (6).

Regulators balanced by a bellows or a diaphragm only differ in the pressure balancing principle applied. The valves balanced by a diaphragm have a balancing diaphragm (4.2) instead of a bellows (4.1). In both cases, the forces created by the upstream and downstream pressures that act on the valve plug are balanced out.

The valves can be supplied with flow divider ST 1 or ST 3. The valve seat must be replaced on retrofitting the flow divider.

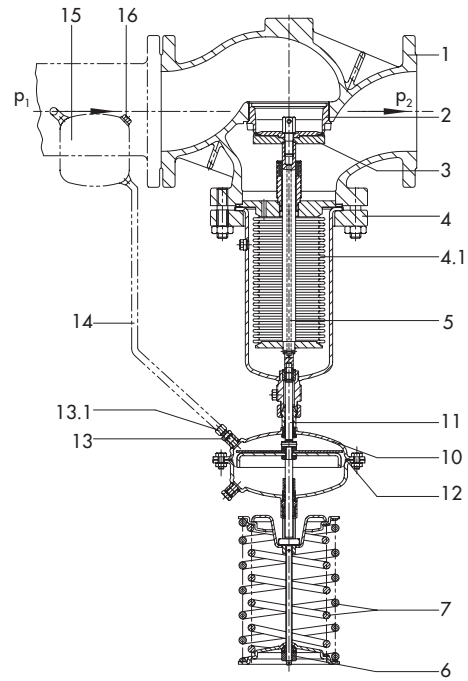

Type 2422/2425 Excess Pressure Valve
Type 2422 Valve · Balanced by a bellows

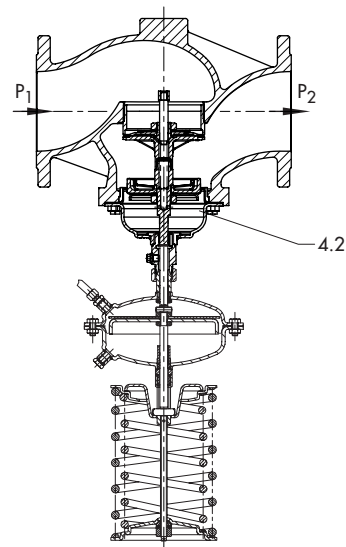

Type 2422/2425 Excess Pressure Valve
Type 2422 Valve · Balanced by a diaphragm

Legend

1 Valve body	12 Operating diaphragm
2 Seat	13 Control line connection G ¼ (with ¼ NPT adapter)
3 Plug	13.1 Screw joint with restriction
4 Bellows housing	14 Control line (to be provided on site)
4.1 Balancing bellows	15 Compensation chamber
4.2 Balancing diaphragm	16 Filler plug
5 Plug stem	p_1 Upstream pressure
6 Set point adjuster	p_2 Downstream pressure
7 Set point springs	
10 Actuator	
11 Actuator stem	

Fig. 2: Functional diagram of Type 2422/2425

Table 1: Technical data · All pressures (gauge)

Type 2422 Valve		NPS 6/DN 150	NPS 8/DN 200	NPS 10/DN 250
Nominal size				
Pressure rating		Class 125, 150 or 300		
Max. permissible temperature	Valve body	See pressure-temperature diagram in ► T 2500		
	Valve plug balanced by a bellows	Metal seal: 660 °F (350 °C) · PTFE soft seal: 430 °F (220 °C) · EPDM or FKM soft seal: 300 °F (150 °C) · NBR soft seal: 175 °F (80 °C)		
	Valve plug balanced by a diaphragm	300 °F/150 °C		
Leakage class according to ANSI/FCI 70-2 or IEC 60534-4		≤0.05 % of C _v /K _{vs} coefficient		
Conformity		CE		
Type 2425 Actuator				
Set point ranges		0.75 to 3.5 psi · 1.5 to 8.5 psi · 3 to 14.5 psi · 7 to 20 psi · 14.5 to 35 psi ¹⁾		
		0.05 to 0.25 bar · 0.1 to 0.6 bar · 0.2 to 1 bar · 0.5 to 1.5 bar · 1 to 2.5 bar ¹⁾		
Max. perm. pressure at actuator	Actuator area	50 in ² /320 cm ²	100 in ² /640 cm ²	
	Pressure	43.5 psi/3 bar	22 psi/1.5 bar	
Max. permissible temperature		Gases, at the actuator 175 °F (80 °C) · Liquids 300 °F (150 °C), with compensation chamber 660 °F (350 °C) · Steam with compensation chamber 660 °F (350 °C)		

¹⁾ Set point ranges above 35 psi (2.5 bar) ► T 2554 Type 2335 Excess Pressure Valve

Table 2: Materials · Material numbers according to ASTM and DIN EN

Type 2422 Valve · Balanced by a bellows			
Pressure rating	Class 125	Class 150/300	
Body	Cast iron A 126 B	Cast steel A216 WCC	Cast stainless steel A351 CF8M
Seat	1.4006		1.4571/1.4404
Plug	1.4571		1.4571/1.4301 with PTFE seal
	Seal for soft-seated plug	PTFE with 15 % glass fiber · EPDM · FKM · NBR	
Plug stem	1.4301		
Balancing bellows	1.4571		
Bottom section	1.0305		1.4571
Seal	Graphite on metal core		
Type 2422 Valve · Balanced by a diaphragm			
Pressure rating	Class 125	Class 150	
Body	Cast iron A 126 B	Cast steel A216 WCC	Cast stainless steel A351 CF8M
Seat	Red brass ¹⁾		
Plug (standard version)	Red brass ¹⁾ · With EPDM soft seal or with PTFE soft seal		
Pressure balancing	Balancing cases made of sheet steel DD11 · EPDM balancing diaphragm for liquids and non-flammable gases or NBR diaphragm for flammable gases		
Gasket	Graphite on metal core		
Type 2425 Actuator			
Diaphragm cases	Sheet steel DD11		1.4301
Diaphragm	EPDM with fabric reinforcement · FKM · NBR		
Guide bushing	DU bushing		PTFE
Seals	EPDM · FKM · NBR		

¹⁾ Special version: 1.4409

Dimensions

Type 2422 Valve · Balanced by a bellows

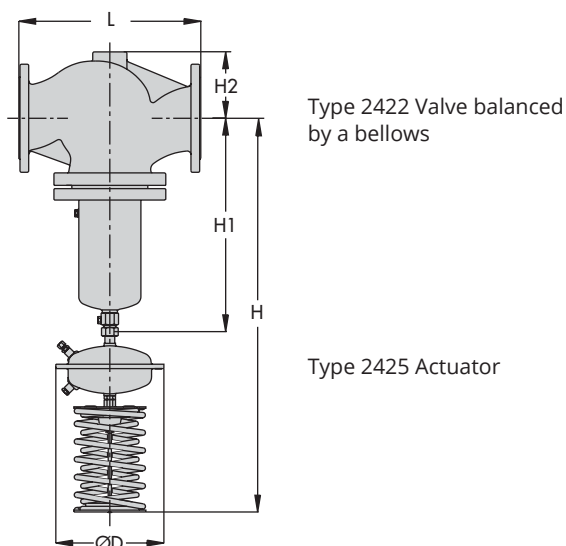

Fig. 3: Dimensional drawing of Type 2422 Valve balanced by a bellows with Type 2425 Actuator

Table 3: Dimensions and weights · Type 2422/2425 · Balanced by a bellows

Nominal size		NPS 6/DN 150	NPS 8/DN 200	NPS 10/DN 250
Valve	Length L	Class 125/150	17.75"/451 mm	21.4"/543 mm
		Class 300	18.6"/473 mm	22.4"/568 mm
	Height H1	23.2"/590 mm (28.4"/730 mm) ²⁾	28.7"/730 mm (34.25"/870 mm) ²⁾	
	Height H2, approx.	6.9"/175 mm	9.25"/235 mm	10.7"/270 mm
Set point range Valve with actuator				
0.75 to 3.5 psi 0.05 to 0.25 bar	Height H	44.1"/1120 mm (49.6"/1260 mm) ²⁾	49.6"/1260 mm (55.1"/1400 mm) ²⁾	
	Actuator	ØD = 15.4"/390 mm · A = 100 in ² /640 cm ²		
1.5 to 8.5 psi 0.1 to 0.6 bar	Height H	44.1"/1120 mm (49.6"/1260 mm) ²⁾	49.6"/1260 mm (55.1"/1400 mm) ²⁾	
	Actuator	ØD = 15.4"/390 mm · A = 100 in ² /640 cm ²		
3 to 14.5 psi 0.2 to 1.0 bar	Height H	44"/1120 mm (49.6"/1260 mm) ²⁾	49.6"/1260 mm (55.1"/1400 mm) ²⁾	
	Actuator	ØD = 15.4"/390 mm · A = 100 in ² /640 cm ²		
7 to 20 psi 0.5 to 1.5 bar	Height H	42.1"/1070 mm (47.6"/1210 mm) ²⁾	47.6"/1210 mm (53.1"/1350 mm) ²⁾	
	Actuator	ØD = 11.2"/285 mm · A = 50 in ² /320 cm ²		
14.5 to 35 psi 1 to 2.5 bar	Height H	42.1"/1070 mm (47.6"/1210 mm) ²⁾	47.6"/1210 mm (53.1"/1350 mm) ²⁾	
	Actuator	ØD = 11.2"/285 mm · A = 50 in ² /320 cm ²		
Weight				
0.75 to 14.5 psi 0.05 to 1.0 bar	Weight ¹⁾ (valve with actuator) for cast iron A216B, Class 125	258 lb/117 kg	633 lb/287 kg	655 lb/297 kg
		245 lb/111 kg	619 lb/281 kg	642 lb/291 kg

¹⁾ Valve in Class 125 with actuator. Class 150: +10 %, Class 300: +15 %

²⁾ Suitable for temperatures above 430 °F (220 °C) to 660 °F (350 °C)

Dimensions

Type 2422 Valve · Balanced by a diaphragm

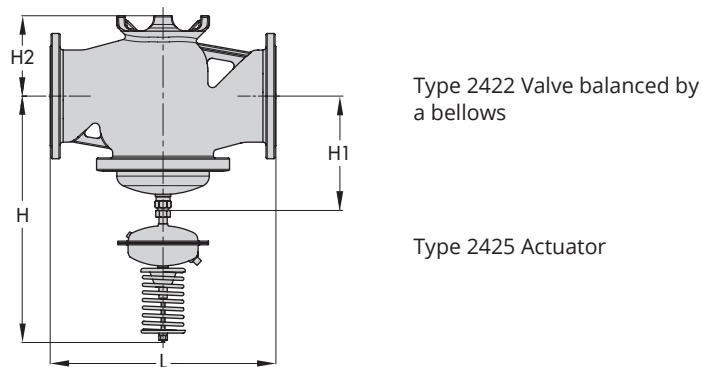

Fig. 4: Dimensional drawing of Type 2422 Valve balanced by a diaphragm with Type 2425 Actuator

Table 4: Dimensions and weights · Type 2422/2425 · **Balanced by a diaphragm**

Nominal size DN		NPS 6/DN 150	NPS 8/DN 200	NPS 10/DN 250
Valve	Length L Class 125 · Class 150	17.75"/451 mm	21.4"/543 mm	26.5"/673 mm
	Height H1	12.2"/310 mm	15"/380 mm	
	Height H2, approx.	6.9"/175 mm	9.25"/235 mm	10.7"/270 mm
Set point range Valve with actuator				
0.75 to 3.5 psi 0.05 to 0.25 bar	Height H	33"/840 mm	35.8"/910 mm	
	Actuator	ØD = 15.4"/390 mm · A = 100 in ² /640 cm ²		
	Weight ²⁾ , approx. kg	207 lb/94 kg	527 lb/239 kg	549 lb/249 kg
1.5 to 8.5 psi 0.1 to 0.6 bar	Height H	33"/840 mm	35.8"/910 mm	
	Actuator	ØD = 15.4"/390 mm · A = 100 in ² /640 cm ²		
	Weight ²⁾ , approx. kg	207 lb/94 kg	527 lb/239 kg	549 lb/249 kg
3 to 14.5 psi 0.2 to 1.0 bar	Height H	36.1"/790 mm	33.9"/860 mm	
	Actuator	ØD = 11.2"/285 mm · A = 50 in ² /320 cm ² ¹⁾		
	Weight ²⁾ , approx. kg	207 lb/94 kg	527 lb/239 kg	549 lb/249 kg
7 to 20 psi 0.5 to 1.5 bar	Height H	31.1"/790 mm	33.9"/860 mm	
	Actuator	ØD = 11.2"/285 mm · A = 50 in ² /320 cm ² ¹⁾		
	Weight ²⁾ , approx. kg	194 lb/88 kg	514 lb/233 kg	536 lb/243 kg
14.5 to 35 psi 1 to 2.5 bar	Height H	36.1"/790 mm	33.9"/860 mm	
	Actuator	ØD = 8.2"/225 mm · A = 50 in ² /320 cm ²		
	Weight ²⁾ , approx. kg	194 lb/88 kg	514 lb/233 kg	536 lb/243 kg

¹⁾ Optionally with actuator 100 in²/640 cm²

²⁾ Valve in Class 125 with actuator. Class 150: +10 %, Class 300: +15 %

Table 5: C_V (K_{VS}) coefficients and max. permissible differential pressures Δp_{max}

Type 2422 Valve · Balanced by a bellows							
C_V (K_{VS}) coefficients and max. permissible differential pressures Δp_{max}							
Nominal size		C_V (K_{VS}) coefficients · Differential pressures			Reduced C_V (K_{VS}) coefficients · Differential pressures		
		NPS 6/DN 150	NPS 8/DN 200	NPS 10/DN 250	NPS 6/DN 150	NPS 8/DN 200	NPS 10/DN 250
Standard C_V (K_{VS}) coefficients	C_V	330	490	585	145	330	330
	K_{VS}	280	420	500	125	280	280
Flow divider ST 1	C_V -ST 1	245	370	440	110	245	245
	K_{VS} -ST 1	210	315	375	95	210	210
Flow divider ST 3	C_V -ST 3	165	230	260	70	165	165
	K_{VS} -ST 3	140	200	220	60	140	140
Max. perm. differential pressure Δp_{max}	psi	175	145	145	230	175	175
	bar	12	10	10	16	12	12
Type 2422 Valve · Balanced by a diaphragm							
C_V (K_{VS}) coefficients and max. permissible differential pressures Δp_{max}							
Nominal size		NPS 6/DN 150		NPS 8/DN 200		NPS 10/DN 250	
C_V / K_{VS} coefficients	C_V coefficient	445		760		930	
	K_{VS} coefficient	380		650		800	
Max. perm. differential pressure Δp_{max}	psi	175		145			
	bar	12		10			

Installation

- Install valve (balanced by a bellows or diaphragm) with the actuator suspended downward.
- Install pipelines horizontally with a slight downward slope on both sides of the valve to prevent condensed water from collecting.
- The direction of flow must match the direction indicated by the arrow on the body.
- Connect a control line to the actuator from the point of pressure tapping located approx. 39" (1 m) upstream of the valve in the pipe wall or at the point of measurement of the connected plant (with compensation chamber, if applicable).



For detailed information on accessories refer to Data Sheet ▶ T 2595

Ordering text

Type 2422/2425 Excess Pressure Valve
 Valve balanced by a bellows or diaphragm
 NPS (DN) ..., body material ..., Class ...
 C_V (K_{VS}) coefficient ..., set point range ... psi (bar)
 Special version ...
 Accessories ...

Accessories

- Screw joints with restriction for connection of the control line e.g. for ¼" or ½" (6 or 12 mm) pipe
- Only applicable to valves balanced by a bellows: compensation chamber for condensation and to protect the operating diaphragm against extreme temperatures. The chamber is required for steam and liquids above 300 °F (150 °C).