

T 2642 EN

Type 2371-00 and Type 2371-01 Excess Pressure Valves for the food and pharmaceutical industries

Series 2371 Pressure Regulators with pneumatic or manual set point adjustment



Application

Excess pressure valves with USP-VI diaphragm for the food and pharmaceutical industries

Set point ranges from **0.3 to 6 bar/5 to 90 psi** · K_{VS} **0.25 to 25/C_V 0.3 to 30** · Valve size **DN 15 to 50/NPS ½ to 2** · Suitable for liquids and gases from **0 to +160 °C/32 to 320 °F** · Max. operating pressure (input pressure) **10 bar/150 psi** · With pneumatic set point adjustment (Type 2371-00) or manual set point adjustment (Type 2371-01)

The valve opens when the input pressure **rises**

Special features

- Proportional pressure regulators for use in the food processing and pharmaceutical industries
- Wetted inside surfaces with a surface roughness $R_a \leq 0.8 \mu\text{m}$; outside surface glass bead blasted
- Stainless steel 1.4404/316L or 1.4409/CF3M
- FDA-compliant materials
- Angle body
- USP Class VI-121 °C compliance
- Body free of dead cavities
- Leakage monitoring of the diaphragm

Versions

Excess pressure valves with diaphragm to control the inlet pressure p_1 to the adjusted set point

The set point adjustment in Type 2371-00 is pneumatic using an external compressed air supply. The set point of Type 2371-01 is adjusted manually by tensioning the set point springs.

Angle valve · Bar-stock version · DN 15 to 50/NPS ½ to 2 · With metal-seated plug or soft-seated special plug · Maximum pressure 10 bar/150 psi

Optionally can be fitted with a stem locking to keep the plug in the open position. This allows the regulator to be cleaned (CIP or SIP) while the valve is open.

Type 2371-00 and **Type 2371-01**: additional version with pneumatic stem locking

Type 2371-01: additional version with manual stem locking

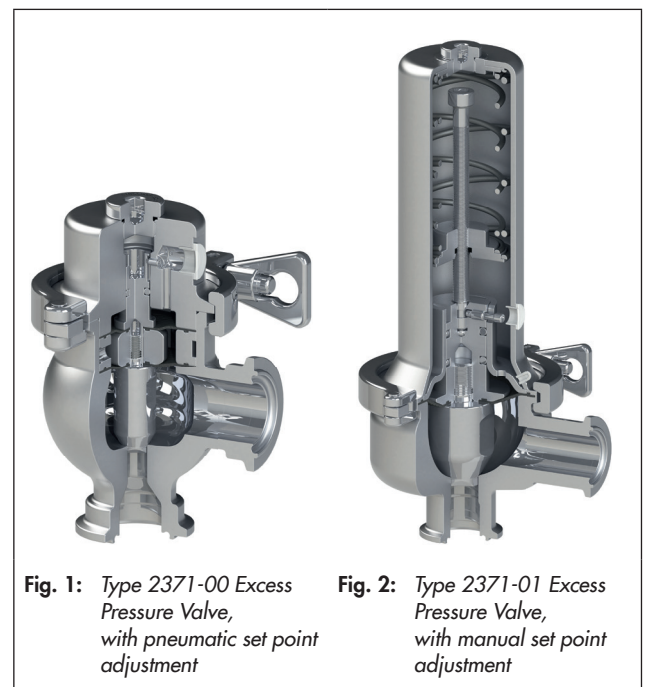

Fig. 1: Type 2371-00 Excess Pressure Valve, with pneumatic set point adjustment

Fig. 2: Type 2371-01 Excess Pressure Valve, with manual set point adjustment

Connections

Welding ends · DIN 11866 Series A = DIN 11850 Series 2/ DIN 11866 Series B/DIN EN ISO 1127 Series 1/DIN 11866 Series C = ASME-BPE 2007 = ASTM A-270 = BS 4825/ DIN EN ISO 1127/ISO 2037/SMS 3008 = NF A 49-249

Threaded connections · DIN 11864-1 GS form A, Series A, B, C/DIN 11887 A Series 1/ISO 2853 = IDF/SMS 1146

Clamp connections · DIN 11864-3 NKS form A, Series A, B, C/DIN 32676 Series A, B, C/ISO 2852/BS 4825 Part 3 = ASME BPE

Flanges · DIN 11864-2 NF form A, Series A, B, C

Special versions

- Material: body and plug in 1.4435, other materials on request
- Valve size: DN 50 body with DN 65 connections
- Plug seal: pure PEEK (Victrex® 450G)
- Inside roughness: $R_a \leq 0.6 \mu\text{m}$ (polished) or $R_a \leq 0.4 \mu\text{m}$ (satin finish or mirror finish)
- External roughness: $R_a \leq 0.6 \mu\text{m}$ (polished)
- End connections: flanges DIN EN 1092-1 B2, ASME B16.5 Class 150, other end connections on request

Principle of operation

The medium flows through the valve body (1) in the direction indicated by the arrow. The position of the plug (3) determines the flow rate across the area released between plug and valve seat (2).

The valve is closed in the normal position. The valve opens when the upstream pressure p_1 rises above the adjusted pressure set point. The resulting input pressure p_1 depends on the flow rate.

Any medium escaping from the test connection (11) indicates that the operating diaphragm (4/4.1) may be leaking or the diaphragm has ruptured.

The test connection of Type 2371-00 ($K_{VS} 25/C_V 30$) is connected to a flexible pipe elbow to discharge any medium escaping.

Type 2371-01: version with manual set point adjustment (see Fig. 3)

In the idle state, the valve is kept closed by the set point springs (7). The valve opens when the input pressure p_1 acting on the diaphragm (4) and the resulting force exceed the force of the springs.

The set point is adjusted using an Allen key (8 mm), which is inserted through the adjustment opening (6.1) on top of the housing onto the set point screw (6). The blanking plug must first be removed. If necessary, the set point screw can be secured by the locking screw (12) in the upper plug section to prevent the set point screw from loosening due to vibrations, causing the set point to change.

Turning the set point screw clockwise causes the spring plate (7.1) to move upwards and increases the spring force and the set point. Turn counterclockwise to relieve tension from the set point spring; the set point is reduced.

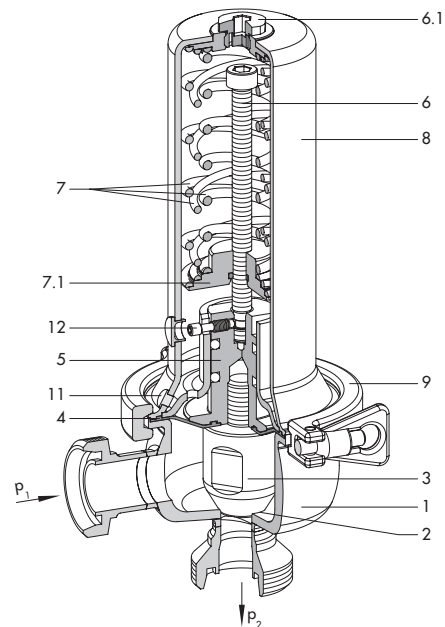

Fig. 3: Type 2371-01 Excess Pressure Valve with manual set point adjustment

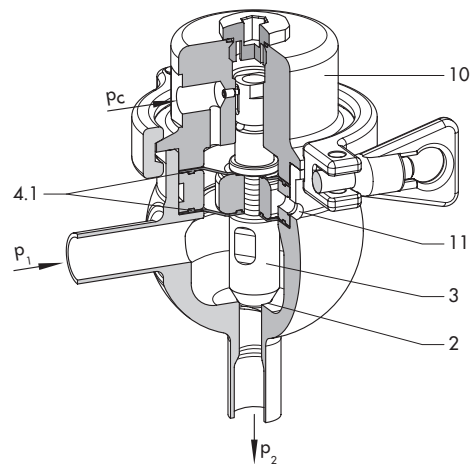

Fig. 4: Type 2371-00 Excess Pressure Valve with pneumatic set point adjustment

- | | |
|-------|--|
| 1 | Valve body |
| 2 | Seat |
| 3 | Plug |
| 4 | Diaphragm (Type 2371-01) |
| 4.1 | Two diaphragms (Type 2371-00) |
| 5 | Upper plug section |
| 6 | Set point screw |
| 6.1 | Adjustment opening with blanking plug |
| 7 | Set point spring(s) |
| 7.1 | Spring plate |
| 8 | Actuator housing with manual set point adjustment |
| 9 | Clamp fitting |
| 10 | Actuator housing with pneumatic set point adjustment |
| 11 | Test bore to monitor the diaphragm for leakage |
| 12 | Locking screw |
| P_c | Set point pressure, external |
| P_1 | Input pressure (upstream pressure) |
| P_2 | Output pressure (downstream pressure) |

Type 2371-00: version with pneumatic set point adjustment (see Fig. 4)

In the idle state, the valve is kept open by the set point pressure p_c ($p_{c \max} = 8 \text{ bar}$).

When the force created by the input pressure p_1 acting on the diaphragm exceeds the force resulting from the set point pressure p_c , the plug (3) moves towards the seat (2), opening the passage. In this case, the ratio between p_1 and p_c is not necessarily 1:1.

As the input pressure p_1 drops, the resulting force reduces again. The valve is closed again when the pressure falls below the set point pressure p_c .

The two diaphragms (4.1) provide a certain amount of safety when one of the diaphragms ruptures and prevents the process medium and external pressure medium (e.g. compressed air) from mixing.

The screw (12) prevents parts from falling apart inadvertently while the regulator is being dismantled.

Stem locking for CIP or SIP

The Type 2371-00 and Type 2371-01 Excess Pressure Valves can be fitted with a stem locking to keep the plug in the open position.

In the version with stem locking, the plug can be locked in the open position to allow the valve to be cleaned (CIP = Cleaning In Place or SIP = Sterilization In Place) while it is open.

The stem can be locked in place pneumatically by an additional pneumatic actuator with compressed air connection (for Types 2371-00/-01) or manually using a lever with clamping fixture (Type 2371-01 only).

The pneumatic and manual stem locking do not affect the control function of the valve, provided the stem locking is not engaged.

The pneumatic unit for the pneumatic stem locking is located on the top of the regulator. The unit can be mounted in any position since the axial fixture of the unit allows it to turn 360°.

The clamping fixture of the manual stem locking is directly connected with the plug over the set point screw to allow the plug stem and plug to be pushed into the open position and locked in place.

Pneumatic stem locking: Type 2371-00 (see Fig. 5)

To open the valve, apply a pressure $p_v = 1 \text{ bar}$ to the pneumatic unit. This causes the plug stem to move together with the plug out of the valve seat. A set point pressure p_c must not be applied to the regulator in this case.

To switch the valve back to its control function, remove the pressure $p_v (= 1 \text{ bar})$. The spring (16) pulls the actuating unit back, allowing the plug stem to move again for the control task.

Apply the set point pressure p_c again for the control task.

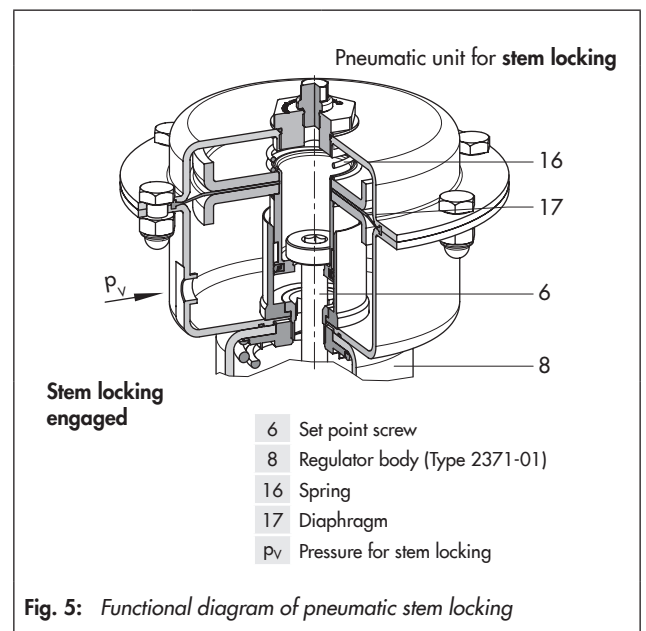

Fig. 5: Functional diagram of pneumatic stem locking

Pneumatic stem locking: Type 2371-01 (see Fig. 5)

To open the valve, apply a pressure $p_v (= 6 \text{ bar})$ to the pneumatic unit. This causes the plug stem to move together with the plug out of the valve seat and opens the valve. To switch the valve back to its control function, remove the pressure $p_v (= 6 \text{ bar})$. The spring (16) pulls the actuating unit back, allowing the plug stem to move again for the control task.

Manual stem locking: Type 2371-01 (see Fig. 6)

Type 2371-01 can also be fitted with a manually operated stem locking.

The lever together with the clamping fixture is directly connected with the plug over the set point screw (1).

When the lever is pushed manually to the other side, the plug is pushed, opposing the spring force, into the open position and locked in place (2).

Push the lever back to allow the regulator to continue its control task.

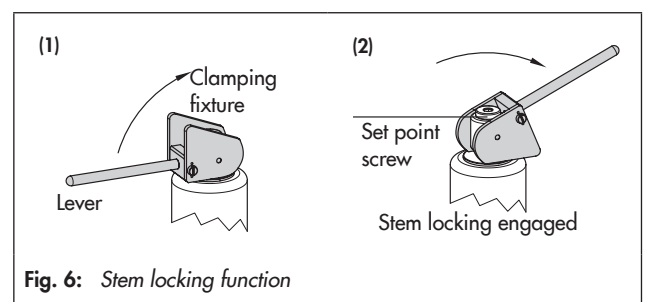

Fig. 6: Stem locking function

Installation

The regulator has an angle-style valve body.

- Install the valve free of stress into the pipeline.

The following points must be observed:

- The valve axis must be vertical (actuator housing on top) and, as a result, the inlet must face to the side in the installed position.
- The direction of flow must match the direction indicated by the arrow on the body (inlet at the side and outlet at the bottom).



Table 1: Technical data · All pressures in psi and bar (gauge)

Types 2371-00/-01 Excess Pressure Valve		DIN					ANSI						
Nominal size		DN 15	DN 20	DN 25	DN 32	DN 40	DN 50	NPS ½	NPS ¾	NPS 1	NPS 1¼	NPS 1½	NPS 2
Set point ranges	Type 2371-00	0.3 to 6 bar					5 to 90 psi						
	Type 2371-01	0.4 to 1.2 bar · 1 to 3 bar · 2.5 to 4.5 bar · 4 to 6 bar					6 to 18 psi · 1.5 to 45 psi · 35 to 65 psi · 60 to 90 psi						
Pneumatic control connection	Type 2371-00	G ¼											
	CIP	G ⅝											
Maximum pressure		10 bar					150 psi						
Max. perm. temperatures	Operating temperature range	0 to +160 °C					32 to 320 °F						
	Sterilization temperature	180 °C for up to 30 minutes					356 °F for up to 30 minutes						
Leakage class according to IEC 60534-4 or ANSI/FCI 70-2		Metal seal: class I (≤ 0.05 % of C_V/K_{VS} coefficient) Soft seal: class IV (≤ 0.01 % of C_V/K_{VS} coefficient)											
Peak-to-valley height and surface finish	External	Glass bead blasted ¹⁾ · Ra ≤ 0.6 μm , polished											
	Internal	Ra ≤ 0.8 μm , precision-lathed ¹⁾ · Ra ≤ 0.6 μm , polished · Ra ≤ 0.4 μm , satin finish · Ra ≤ 0.4 μm , mirror finish											
Conformity		CE EAC											

¹⁾ Standard version

Table 2: K_{VS} and C_V coefficients

Nominal size	DN 15	DN 20	DN 25	DN 32	DN 40	DN 50	NPS ½	NPS ¾	NPS 1	NPS 1¼	NPS 1½	NPS 2
Version	DIN (K_{VS} coefficient)						ANSI (C_V coefficient)					
Excess pressure valve	Type 2371-00											
K_{VS}/C_V coefficients (standard)	0.25		1.0		0.3		1.2					
	0.63		2.5		0.75		3.0					
	2.5		4.0		3.0		5.0					
	–		10		–		12					
K_{VS}/C_V coefficients (high)	–		25		–		30					
Excess pressure valve	Type 2371-01											
K_{VS}/C_V coefficients	0.25		1.0		0.3		1.2					
	0.63		2.5		0.75		3.0					
	1.6		4.0		2.0		5.0					
	2.5		10		3.0		12					

Table 3: Materials · Material numbers according to ASTM and DIN EN

Excess pressure valve		Type 2371-00 (high K_{VS}/C_V coefficients)		Type 2371-00/-01 (standard K_{VS}/C_V coefficients)	
Version		DIN	ANSI	DIN	ANSI
Body, spring housing		1.4409	CF3M	1.4404	316 L
Plug	Metal seal	1.4409	CF3M	1.4404	316 L
	Seal for soft-seated plug	EPDM			
Diaphragm		PTFE-coated EPDM			
Springs		1.4310			

Type 2371-00 · Regulator with pneumatic set point adjustment

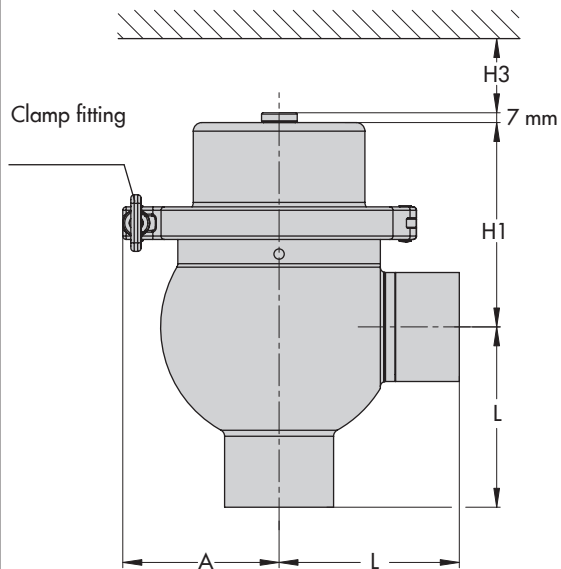

Type 2371-00 · DN 15 to 25/NPS ½ to 1
Without stem locking

The clamp fitting is turned 90° in the drawing.

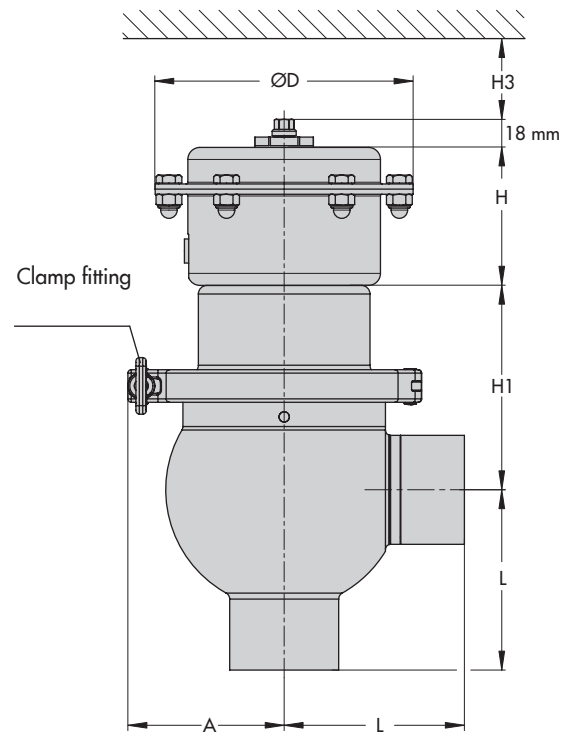

Type 2371-00 · DN 32 to 50/NPS 1¼ to 2
With pneumatic stem locking

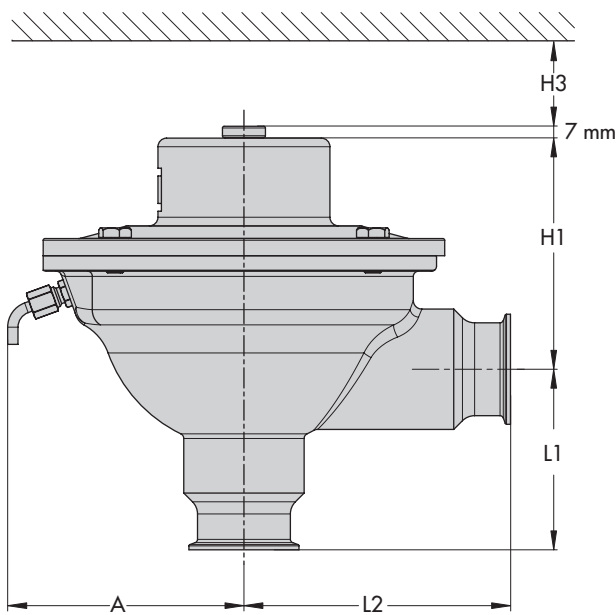

Type 2371-00 · DN 32 to 50, K_{VS} 25/NPS 1¼ to 2, C_V 30
Without stem locking

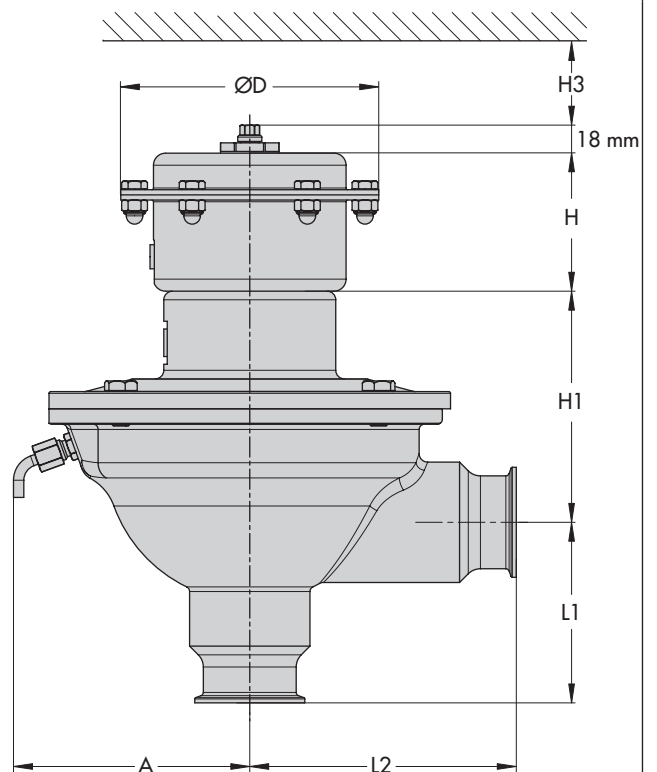

Type 2371-00 · DN 32 to 50, K_{VS} 25/NPS 1¼ to 2, C_V 30
With pneumatic stem locking

The dimensions of the stem locking are the same for all valve sizes of the regulators.

Fig. 7: Dimensional drawings for Type 2371-00

Type 2371-01 · Regulator with manual set point adjustment

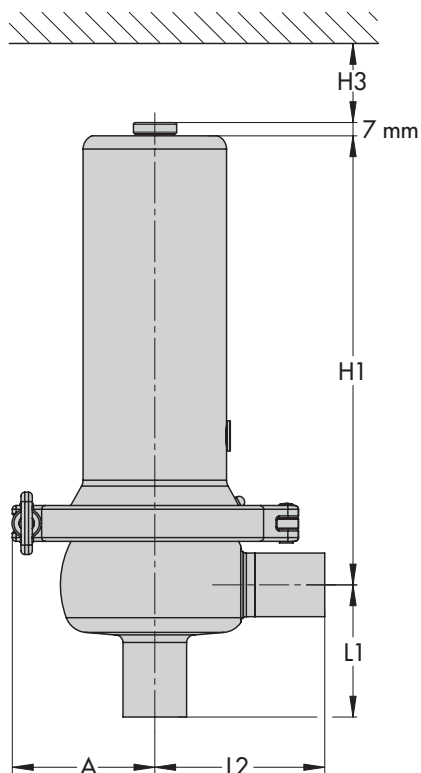

Type 2371-01 · DN 15 to 25/NPS ½ to 1

The clamp fitting is turned 90° in the drawing.

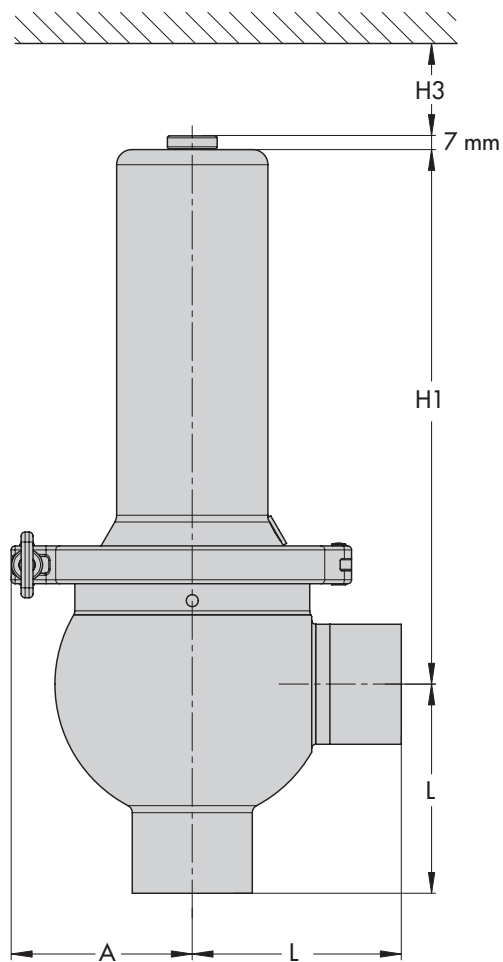

Type 2371-01 · DN 32 to 50/NPS 1¼ to 2

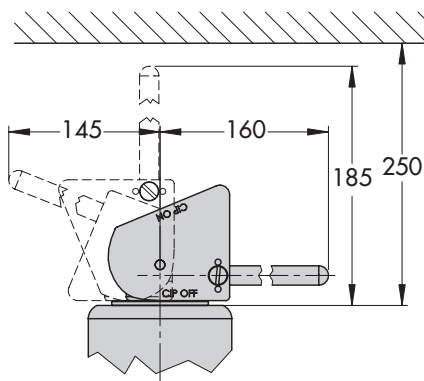

Type 2371-01 · With manual stem locking

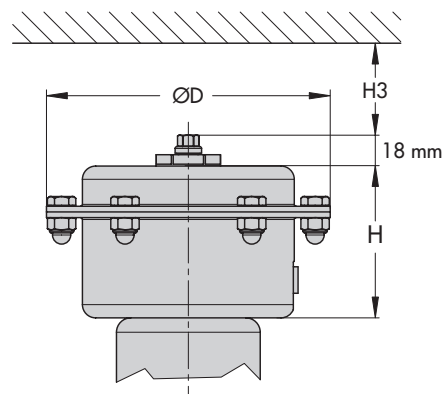

Type 2371-01 · With pneumatic stem locking

Type 2371-01 with welding ends is shown in these drawings.
The dimensions of the stem locking are the same for all valve sizes of the regulators.

Fig. 8: Dimensional drawings for Type 2371-01

Dimensions - End connections
See Table 4 to Table 8

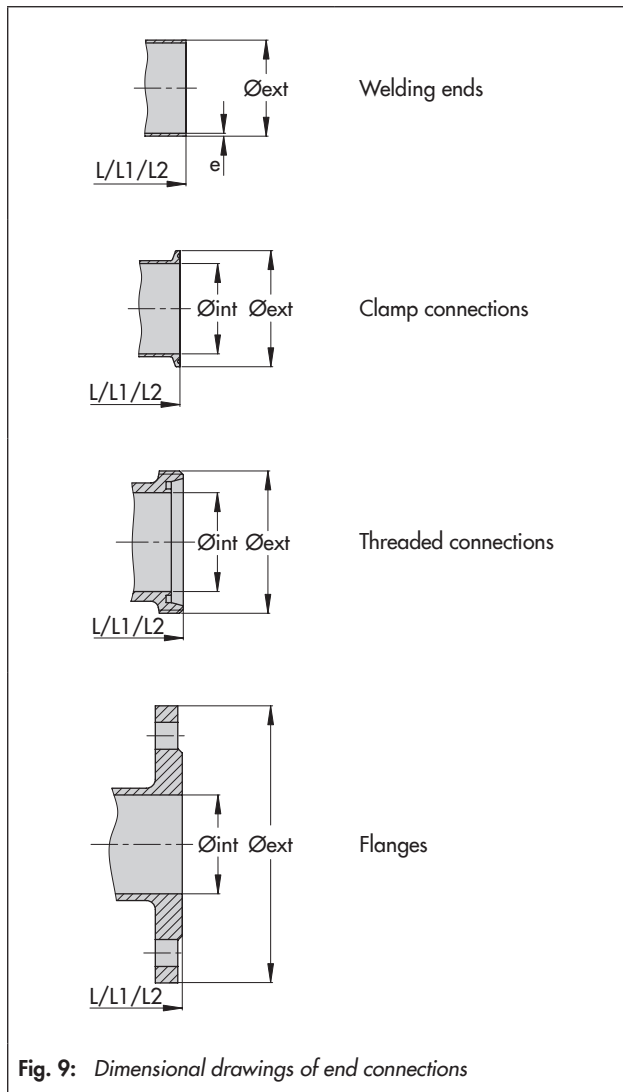

Fig. 9: Dimensional drawings of end connections

Ordering text

Type 2371-00 and Type 2371-01 Excess Pressure Valves

Type 2371-00 · Pneumatic set point adjustment

Set point range ...

Type 2371-01 · Manual set point adjustment

Set point range ...

K_{VS} coefficient/ C_V coefficient ...

Valve size DN .../NPS ...

Plug with metal/soft seal

Type of connection:

Threaded connection according to ...

Clamp connections according to ...

Flange connection according to ...

Welding ends according to ...

Stem locking: pneumatic/manual

Table 4: Clamp connections · All dimensions in mm

Excess pressure valve		Types 2371-00/-01						Type 2371-00 (K _{V5} /C _V 25/30)		
Nominal size		DN 15 NPS ½	DN 20 NPS ¾	DN 25 NPS 1	DN 32 NPS 1¼	DN 40 NPS 1½	DN 50 NPS 2	DN 32 NPS 1¼	DN 40 NPS 1½	DN 50 NPS 2
DIN 11864-3 NKS form A, Series A	P _{max}	10 bar · 150 psi								
	L	60.3			88.9			-		
	L1	60			88.9			105		
	L2	90			88.9			155		
	Ø _{int}	16	20	26	32	38	50	32	38	50
	Ø _{ext}	34	50.5			64	77.5	50.5	64	77.5
DIN 11864-3 NKS, Form A, Series B	P _{max}	10 bar · 150 psi								
	L	60.3			88.9			-		
	L1	60			88.9			105		
	L2	90			88.9			155		
	Ø _{int}	18.1	23.7	29.7	38.4	44.3	56.3	38.4	44.3	56.3
	Ø _{ext}	34	50.5			64	91	64		91
DIN 11864-3 NKS Form A, Series C	P _{max}	10 bar · 150 psi								
	L	60.3			-	88.9		-		
	L1	60			-	88.9		-	105	
	L2	90			-	88.9		-	155	
	Ø _{int}	9.4	15.75	22.1	-	34.8	47.5	-	34.8	47.5
	Ø _{ext}	34		50.5	-	64	77.5	-	64	77.5
DIN 32676, Series A	P _{max}	10 bar · 150 psi								
	L	60.3			88.9			-		
	L1	60			88.9			105		
	L2	90			88.9			155		
	Ø _{int}	16	20	26	32	38	50	32	38	50
	Ø _{ext}	34		50.5			64	50.5		64
DIN 32676, Series B	P _{max}	10 bar · 150 psi								
	L	60.3			88.9			-		
	L1	60			88.9			105		
	L2	90			88.9			155		
	Ø _{int}	18.1	23.7	29.7	38.4	44.3	56.3	38.4	44.3	56.3
	Ø _{ext}	50.5			64		77.5	64		77.5
DIN 32676, Series C	P _{max}	10 bar · 150 psi								
	L	60.3			-	88.9		-		
	L1	60			-	88.9		-	105	
	L2	90			-	88.9		-	155	
	Ø _{int}	9.4	15.75	22.1	-	34.8	47.5	-	34.8	47.5
	Ø _{ext}	25		50.5	-	50.5	64	-	50.5	64
ISO 2852	P _{max}	10 bar · 150 psi								
	L	-	60.3	88.9			-			
	L1	-	60	88.9			105			
	L2	-	90	88.9			155			
	Ø _{int}	-	22.6	31.3	35.6	48.6	31.3	35.6	48.6	
	Ø _{ext}	-	50.5			64	50.5		64	
BS 4825 Part 3 = ASME BPE	P _{max}	10 bar · 150 psi								
	L	60.3 ¹⁾		60.3	-	88.9		-		
	L1	60 ¹⁾		60	-	88.9		-	105	
	L2	90 ¹⁾		90	-	88.9		-	155	
	Ø _{int}	9.4 ¹⁾	15.75 ¹⁾	22.2	-	34.9	47.6	-	34.9	47.6
	Ø _{ext}	25 ¹⁾		50.5	-	50.5	64	-	50.5	64

¹⁾ Version according to ASME BPE only

Table 5: Welding ends · All dimensions in mm

Excess pressure valve		Types 2371-00/-01						Type 2371-00 (K _{V5} /C _V 25/30)			
		DN 15 NPS ½	DN 20 NPS ¾	DN 25 NPS 1	DN 32 NPS 1¼	DN 40 NPS 1½	DN 50 NPS 2	DN 32 NPS 1¼	DN 40 NPS 1½	DN 50 NPS 2	
DIN 11866, Series A = DIN 11850, Series 2	P _{max}	10 bar · 150 psi									
	L	70			105			-			
	L1	70			105						
	L2	90			105			155			
	Ø _{ext}	19	23	29	35	41	53	35	41	53	
	e	1.5									
	DIN 11866, Series B	P _{max}	10 bar · 150 psi								
L		70			105			-			
L1		70			105						
L2		90			105			155			
Ø _{ext}		21.3	26.9	33.7	42.4	48.3	60.3	42.4	48.3	60.3	
e		1.6			2						
DIN 11866 Series C = ASME-BPE 2007 = ASTM -270 = BS 4825		P _{max}	10 bar · 150 psi								
	L	70			-	105		-			
	L1	70			-	105		-	105		
	L2	90			-	105		-	155		
	Ø _{ext}	12.7	19.05	25.4	-	38.1	50.8	-	38.1	50.8	
	e	1.65		+0 -0.1	-	1.65	+0 -0.1	-	1.65	+0 -0.1	
	DIN EN ISO 1127, Series 1	P _{max}	10 bar · 150 psi								
L		70			105			-			
L1		70			105						
L2		90			105			155			
Ø _{ext}		21.3	26.9	33.7	42.4	48.3	60.3	42.4	48.3	60.3	
e		1.6			2			2.6	2		2.6
ISO 2037		P _{max}	10 bar · 150 psi								
	L	70			105			-			
	L1	70			105						
	L2	90			105			155			
	Ø _{ext}	17.2	21.3	25	33.7	38	51	33.7	38	51	
	e	1			1.2						
	SMS 3008 = NF A 49-249	P _{max}	10 bar · 150 psi								
L		-	70		105			-			
L1		-	70		105						
L2		-	90		105			155			
Ø _{ext}		-	25		33.7	38	51	33.7	38	51	
e		-	1.2								

Table 6: Threaded connections · All dimensions in mm

Excess pressure valve		Types 2371-00/-01					Type 2371-00 (K _{v5} /C _v 25/30)			
Nominal size		DN 15 NPS ½	DN 20 NPS ¾	DN 25 NPS 1	DN 32 NPS 1¼	DN 40 NPS 1½	DN 50 NPS 2	DN 32 NPS 1¼	DN 40 NPS 1½	DN 50 NPS 2
DIN 11864-1 GS form A, Series A	P _{max}	10 bar · 150 psi								
	L	64			100			-		
	L1	60			100			105		
	L2	90			100			155		
	Ø _{int}	16	20	26	32	38	50	32	38	50
	Ø _{ext}	RD 34x½"	RD 44x½"	RD 52x½"	RD 58x½"	RD 65x½"	RD 78x½"	RD 58x½"	RD 65x½"	RD 78x½"
DIN 11864-1 GS form A, Series B	P _{max}	10 bar · 150 psi								
	L	64			100			-		
	L1	60			100			105		
	L2	90			100			155		
	Ø _{int}	18.1	23.7	29.7	38.4	44.3	56.3	38.4	44.3	56.3
	Ø _{ext}	RD 44x½"	RD 52x½"	RD 58x½"	RD 65x½"	RD 78x½"	RD 95x½"	RD 65x½"	RD 78x½"	RD 95x½"
DIN 11864-1 GS form A, Series C	P _{max}	10 bar · 150 psi								
	L	64			-	100		-		
	L1	60			-	100		-	105	
	L2	90			-	100		-	155	
	Ø _{int}	9.4	15.75	22.1	-	34.8	47.5	-	34.8	47.5
	Ø _{ext}	RD 28x½"	RD 34x½"	RD 52x½"	-	RD 65x½"	RD 78x½"	-	RD 65x½"	RD 78x½"
DIN 11887 A, Series 1	P _{max}	10 bar · 150 psi								
	L	64			100			-		
	L1	60			100			105		
	L2	90			100			155		
	Ø _{int}	16	20	26	32	38	50	32	38	50
	Ø _{ext}	RD 34x½"	RD 44x½"	RD 52x½"	RD 58x½"	RD 65x½"	RD 78x½"	RD 58x½"	RD 65x½"	RD 78x½"
ISO 2853 = IDF	P _{max}	10 bar · 150 psi								
	L	-	64	100			-			
	L1	-	60	100			105			
	L2	-	90	100			155			
	Ø _{int}	-	22.6	31.3	35.6	48.6	31.3	35.6	48.6	
	Ø _{ext}	-	37x½"	45.9x½"	50.6x½"	64.1x½"	45.9x½"	50.6x½"	64.1x½"	
SMS 1146	P _{max}	6 bar · 87 psi								
	L	-	55	105			-			
	L1	-	60	105						
	L2	-	90	105			155			
	Ø _{int}	-	22.6	29.6	35.6	48.6	29.6	35.6	48.6	
	Ø _{ext}	-	RD 40x½"	RD 48x½"	RD 60x½"	RD 70x½"	RD 48x½"	RD 60x½"	RD 70x½"	

Table 7: Flanges · All dimensions in mm

Excess pressure valve		Types 2371-00/-01						Type 2371-00 (K _{V5} /C _V 25/30)		
Nominal size		DN 15 NPS ½	DN 20 NPS ¾	DN 25 NPS 1	DN 32 NPS 1¼	DN 40 NPS 1½	DN 50 NPS 2	DN 32 NPS 1¼	DN 40 NPS 1½	DN 50 NPS 2
DIN 11864-2 NF form A, Series A	P _{max}	10 bar · 150 psi								
	L	90	95	100	105	115	125	-		
	L1	90	95	100	105	115	125	105		
	L2	90	95	100	105	115	125	155		
	Ø _{int}	16	20	26	32	38	50	32	38	50
	Ø _{ext}	59	64	70	76	82	94	76	82	94
DIN 11864-2 NF form A, Series B	P _{max}	10 bar · 150 psi								
	L	90	95	100	105	115	125	-		
	L1	90	95	100	105	115	125	105		
	L2	90	95	100	105	115	125	155		
	Ø _{int}	18.1	23.7	29.7	38.4	44.3	56.3	38.4	44.3	56.3
	Ø _{ext}	62	69	74	82	88	103	82	88	103
DIN 11864-2 NF form A, Series C	P _{max}	10 bar · 150 psi								
	L	90	95	100	-	115	125	-		
	L1	90	95	100	-	115	125	-	105	
	L2	90	95	100	-	115	125	-	155	
	Ø _{int}	9.4	15.75	22.1	-	34.8	47.5	-	34.8	47.5
	Ø _{ext}	54	59	66	-	79	92	-	79	92
DIN EN 1092-1 B2 or ASME B16.5 Class 150		On request								

Table 8: General · All dimensions in mm

Excess pressure valve		Types 2371-00/-01						Type 2371-00 (K _{V5} /C _V 25/30)		
Nominal size		DN 15 NPS ½	DN 20 NPS ¾	DN 25 NPS 1	DN 32 NPS 1¼	DN 40 NPS 1½	DN 50 NPS 2	DN 32 NPS 1¼	DN 40 NPS 1½	DN 50 NPS 2
Common dimensions	A	70			100			145		
	H	85			100			-		
	H1	80			120			135		
	H1	240			290			-		
	H3				≥ 200					
	ØD				150					
	Weight, approx. kg									
Type 2371-00		3			11			15		
Type 2371-01		8.5			12			-		
Version with stem locking										
Pneumatic unit					+2.5					
Manual stem locking					+0.7					

