

T 5827 EN**Type 5827 Electric Actuator****Application**

Electric actuator designed for valves used in heating, ventilation and air-conditioning systems, process engineering and industrial energy transfer systems



Fig. 1: Type 5827 Electric Actuator

Special features

The linear actuator is particularly suitable for attachment to SAMSON Types 3260, 3222, 3226, 3213, 3214 and V2001 Valves. In addition, it can be used as an additional electric actuator on self-operated differential pressure and flow regulators.

- Actuator with or without fail-safe action
- Motor switched off by torque switches
- Manual override (handwheel, only version without fail-safe action)
- No maintenance

Versions

- Version with three-step signal
 - Synchronous motor with maintenance-free gearing
 - Synchronous motor with double stroking speed and maintenance-free gearing
- Digital positioner
 - Stepper motor with maintenance-free gearing
 - Adjustment of the direction of action at the actuator
 - Start-up at the actuator
 - Settings made using the TROVIS-VIEW software

Options

- Faster motor
 - Double stroking speed possible (version with three-step signal)
- Limit contacts
 - Two adjustable mechanical changeover switches
- Resistance transmitter
 - One resistance transmitter with a resistance range from 0 to 1000 Ω

Device code

Type 5827- Electric Actuator	x	x	x
Fail-safe action			
Without	N		
Actuator stem extends	A		
Actuator stem retracts	E		
Rated travel/adaptation			
6 mm/force-locking	1		
12 mm/force-locking	2		
15 mm/form-fit	3		
Control/supply voltage			
Three-step control/230 V AC			1
Three-step control/24 V AC			2
Positioner/24 V AC and DC			4
Positioner/85 to 264 V AC			5

Design and principle of operation

The Type 5827 Electric Actuator is linear actuator, which is used in combination with SAMSON valves in industrial plants as well as in heating, ventilation and air-conditioning systems.

Depending on the actuator version, either a three-step signal or continuous signal issued by an electronic controller is used to control the electric actuator. The electric actuator consists of a reversible motor and a maintenance-free planetary gear with ball screw drive. The motor is switched off by torque switches in the end positions or in case of overload.

The force of the motor is transmitted to the actuator stem (3) via gearing and crank disk. When the actuator stem extends, the actuator piston (3) pushes against the valve's plug stem. When the actuator stem retracts (force-locking attachment), the plug stem follows the movement of the actuator stem as a result of the return spring in the valve.

When the actuator stem retracts (form-fit attachment), the plug stem is connected to the actuator stem and follows its movement.

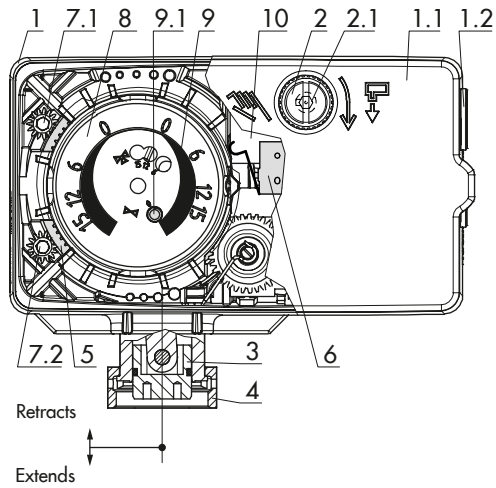

Fig. 2: Design of Type 5827 (force-locking attachment)

- 1 Housing
- 1.1 Front housing cover
- 1.2 Cable entry
- 2 Handwheel (Type 5827-Nxx only)
- 2.1 Actuating shaft
- 3 Actuator stem with actuator piston
- 4 Coupling nut
- 5 Cam disk
- 6 Mechanical limit contacts
- 7.1 Adjuster for limit contact (bottom contact cam)
- 7.2 Adjuster for limit contact (top contact cam)
- 8 Spring assembly (Types 5827-Axx and 5827-Exx only)
- 9 Travel indication scale
- 9.1 Driving pin
- 10 Torque switch

Fail-safe action

The Type 5827 Actuator is available with fail-safe action. The actuators with fail-safe action have a spring assembly and an electromagnet. The actuator is moved by the force of the spring to the fail-safe position when the electromagnet is de-energized. The direction of action depends on the actuator version and cannot be reversed.

- **“Actuator stem extends” fail-safe action:**
The actuator stem extends upon supply voltage failure.
- **“Actuator stem retracts” fail-safe action:**
The actuator stem retracts upon supply voltage failure.

Electric actuators with fail-safe action do not have a handwheel. After disconnecting the supply voltage and opening the front housing cover, manual operation is possible with an Allen key. The actuator returns to its original position as soon as the Allen key is released.

Testing according to DIN EN 14597

Type 5827 Electric Actuators with "Actuator stem extends" fail-safe action which have a test mark on their nameplate are tested by the German technical surveillance association TÜV according to DIN EN 14597 in combination with different SAMSON valves (the register number is available on request).

Limit contacts

Optionally, the actuator can be equipped with two adjustable mechanical limit contacts. They are actuated by continuously adjustable cam disks. The actuator with positioner is only available with adjustable limit contacts in the version for 24 V AC/DC supply voltage.

It is not possible to retrofit limit contacts.

Version with three-step signal

A three-step signal issued by an electronic controller is used to control the electric actuator. The control signal of the controller is connected to the eL and aL terminals of the actuator. Voltage applied to eL causes the actuator motor to retract the actuator stem. Voltage applied to aL causes the actuator motor to extend the actuator stem. The motor is switched off by torque switches or in case of overload.

Actuator with faster motor

The Types 5827-x11, -x21 and -x31 Actuators are equipped with a faster motor in a housing attached to the back of the actuator.

Resistance transmitters

Optionally, the actuator can be equipped with a resistance transmitter. It consists of a potentiometer, which is linked to the gearing of the actuator over a gear wheel. It produces a resistance signal proportional to the travel. The resistance value, which is proportional to the valve travel, can be used for position feedback.

This version is always fitted with limit contacts as well.

Non-floating torque switches

The actuator version with three-step signal is equipped with two fixed torque switches.

They switch the control signal to a separate terminal after the end position is reached. This allows a further actuator to be controlled.

Version with digital positioner

The positioner ensures a predetermined assignment of the valve position to the control signal. For position feedback, a 0 to 10 V signal can be picked off at the output. The characteristic can be reversed. The actuator can be used for split-range operation.

- Automatic zero calibration after connecting the supply voltage
- Direction of action reversed by slide switch
- Momentary travel calculated based on the transit time
- Operating status and errors indicated by LEDs
- Adjustable stroking speed
- Blocking protection
- Adjustable input and output signal ranges
- Configuration, parameterization, diagnostic function and online connection for monitoring using the TROVIS-VIEW software
- Direct data transmission using a connecting cable (direct connection to computer)
- Data transmission over a memory pen

Settings

The digital positioner settings can be changed in the TROVIS-VIEW software.

Table 1: Settings with TROVIS-VIEW

Configuration	Default setting	Adjustment range
Input signal		
Lower range value	0.0 V 0.0 mA	0.0 to 7.5 V 0.0 to 15.0 mA
Upper range value	10.0 V 20.0 mA	2.5 to 10.0 V 5.0 to 20.0 mA
Unit	V	V/mA
Position feedback signal		
Lower range value	0.0 V	0.0 to 10.0 V
Upper range value	10.0 V	0.0 to 10.0 V
Functions		
Detect input signal failure	No	Yes/No
Positioning value upon input signal failure	Internal positioning value	Internal positioning value/last travel value
Internal positioning value	0.0 %	0.0 to 100 %
Value below limit (end position guiding)	1.0 %	0.0 to 49.9 %
Value above limit (end position guiding)	97.0 %	50.0 to 100.0 %
Blockage		
Blocking protection	No	Yes/No
Travel		
Limited travel range	100.0 %	30.0 to 100 %
Travel adjustment	Absolute	Absolute/Relative
Speed	Normal	Slow/Normal/Fast
Dead band (switching range)	2.0 %	0.5 to 5.0 %
Characteristic type	Linear	Linear/Equal percentage/Reverse equal percentage/User-defined

Replacement of old actuators with new actuators (valve is retained)

Old actuator		New actuator	
Type	5824-10	Type	5827-N1x
	5824-13 ¹⁾		5827-N1x
	5824-20		5827-N2x
	5824-23 ¹⁾		5827-N2x
	5824-30		5827-N3x
	5824-33 ¹⁾		5827-N3x
	5825-10		5827-A1x
	5825-11 ²⁾		5827-A1x
	5825-13 ¹⁾		5827-A1x
	5825-15		5827-E1x
	5825-20		5827-A2x
	5825-23 ¹⁾		5827-A2x
	5825-25		5827-E2x
	5825-30		5827-A3x
	5825-33 ¹⁾		5827-A3x
	5825-35		5827-E3x

¹⁾ Double stroking speed no longer covered by the type designation suffix

²⁾ Actuator with slower motor no longer available; replace it with an actuator with normal stroking speed.

Electrical connection

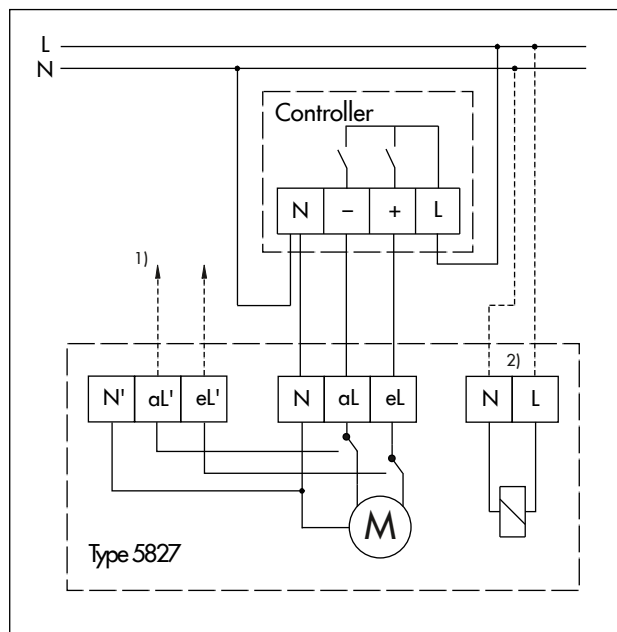

Fig. 3: Electrical connection · Three-step version

¹⁾ Signal feedforward for cascade control of several actuators after an actuator reaches its end position

²⁾ Types 5827-A and 5827-E Actuators with fail-safe action only
The 'N' connection is not connected to the N terminals for actuator control. As a result, it is possible to connect an external supply for 'L' and 'N' connections of the safety circuit.

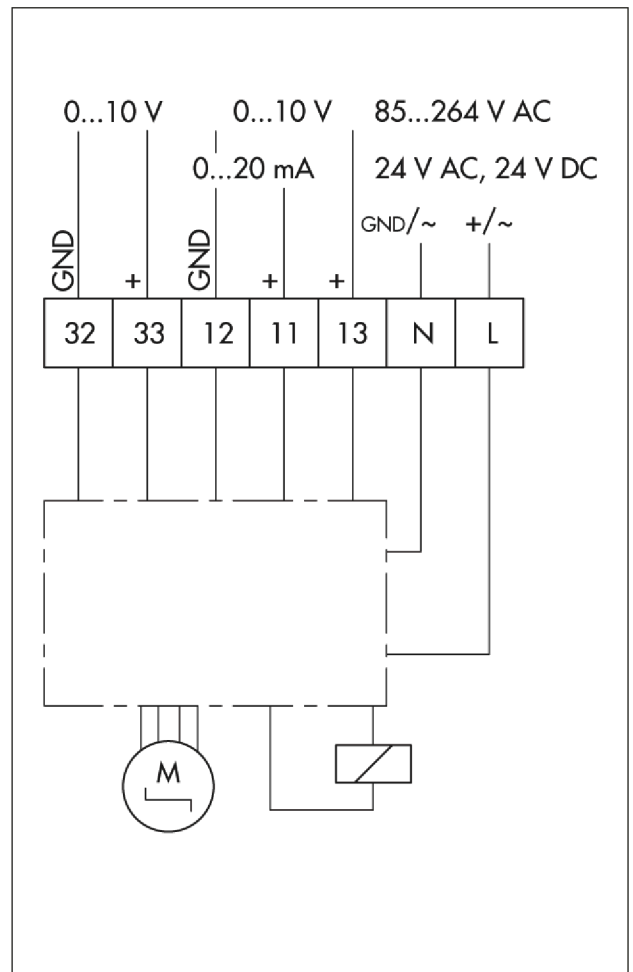

Fig. 4: Electrical connection · Positioner

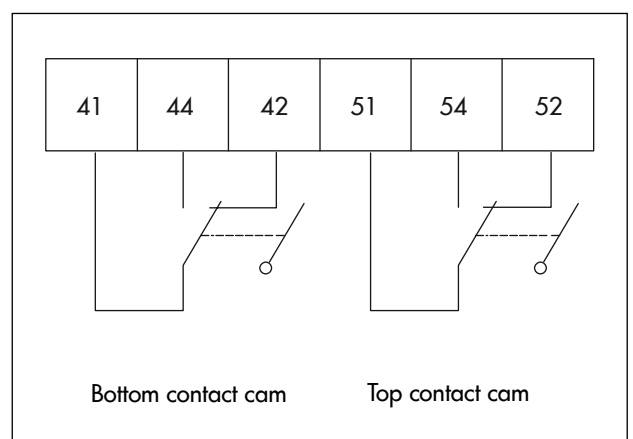

Fig. 5: Electrical connection · Limit contacts

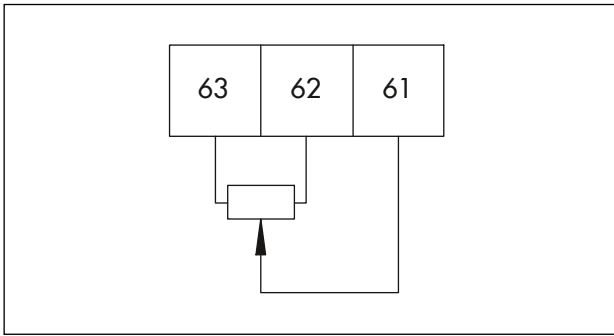

Fig. 6: Electrical connection · Resistance transmitter

(resistance transmitter only in version with three-step signal)

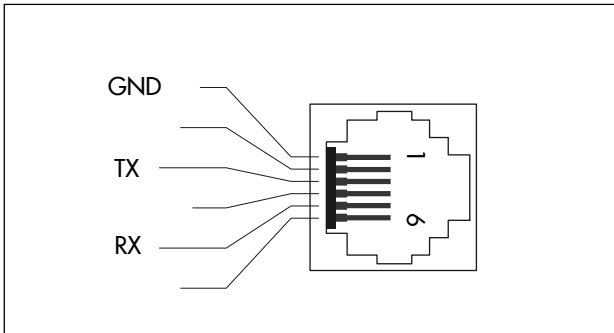

Fig. 7: Assignment of the RJ-12 jack

(RJ-12 jack only on version with positioner)

Technical data

Table 2: Technical data · Type 5827-Nxx, version without fail-safe action

Type 5827-N		11	12	21	22	31	32	14	15	24	25	34	35
Actuation		Three-step						Positioner					
Rated travel in mm		6 ¹⁾	6 ¹⁾	12	12	15	15	6 ¹⁾	6 ¹⁾	12	12	15	15
Thrust in N	Extends	700	700	700	700	700	700	700	700	700	700	700	700
	Retracts	-	-	-	-	700	700	-	-	-	-	700	700
Manual override		✓	✓	✓	✓	✓	✓	✓	✓	✓	✓	✓	✓
Stroking speed in mm/s (adjustable in version with positioner)													
	Slow	-	-	-	-	-	-	0.13	0.13	0.13	0.13	0.13	0.13
	Normal	0.18	0.18	0.18	0.18	0.18	0.18	0.2	0.2	0.2	0.2	0.2	0.2
	Fast	0.36	-	0.36	-	0.36	-	0.36	0.36	0.36	0.36	0.36	0.36
Transit time in s for rated travel													
	Slow	-	-	-	-	-	-	45	45	89	89	111	111
	Normal	35	35	70	70	90	90	31	31	61	61	76	76
	Fast	18	-	35	-	45	-	17	17	33	33	41	41
Attachment	Force-locking	✓	✓	✓	✓	-	-	✓	✓	✓	✓	-	-
	Form-fit	-	-	-	-	✓	✓	-	-	-	-	✓	✓
Supply voltage													
	24 V (±10 %), 50 Hz	-	✓	-	✓	-	✓	-	-	-	-	-	-
	230 V (±10 %), 50/60 Hz ²⁾ Protection provided by electrical installation in the building	✓	-	✓	-	✓	-	-	-	-	-	-	-
	24 V (±10 %), 50 and 60 Hz 24 V DC (-10, +20 %) ³⁾	-	-	-	-	-	-	✓	-	✓	-	✓	-
	100 to 240 V (tolerance 85 to 264 V), 50 to 60 Hz (tolerance 47 to 63 Hz)	-	-	-	-	-	-	-	✓	-	✓	-	✓
Input signal		-						0 to 10 V, R _i = 20 kΩ · 0 to 20 mA, R _i = 50 Ω					
Output signal		-						0 to 10 V, R _B = 1 kΩ					
Power consumption in VA		3 ⁴⁾	3	3 ⁴⁾	3	3 ⁴⁾	3	5 ⁵⁾	8	5 ⁵⁾	8	5 ⁵⁾	8
Torque switch, active switching output		Max. 240 V, max. 1 A						-					
Weight in kg		0.75 ⁶⁾	0.75	0.75 ⁶⁾	0.75	0.75 ⁶⁾	0.75	0.75	0.75	0.75	0.75	0.75	0.75
Additional equipment (cannot be retrofitted)													
	Two limit contacts, max. 240 V, max. 1 A, without contact protection ⁷⁾	✓	✓	✓	✓	✓	✓	✓	-	✓	-	✓	-
	Resistance transmitter ⁸⁾ 0 to 1000 Ω ±15 %, max. 200 mW (90 % of final value at rated travel)	✓	✓	✓	✓	✓	✓	-	-	-	-	-	-

¹⁾ Actuators with 6 mm travel can also be used for valves with 7.5 mm travel.

²⁾ 60 Hz as special version

³⁾ When the fast stroking speed setting is selected, the supply voltage must not fall below the specified value.

⁴⁾ Power consumption doubles for version with faster motor



⁵⁾ Power consumption of 24 V DC version specified in W

⁶⁾ The weight of the version with faster motor is 0.25 kg heavier.

⁷⁾ Contact protection with suitable spark suppression must be fitted for the switching contact. Observe the manufacturer's specifications concerning the connected load to select the appropriate spark suppression. A fuse, which is suitable for the application's circuit, must be used for the short-circuit and overload protection.

⁸⁾ Not possible in actuator with faster motor

Table 3: Technical data · Type 5827-Axx, version with "actuator stem extends" fail-safe action

Type 5827-A		11	12	21	22	31	32	14	15	24	25	34	35
Actuation		Three-step						Positioner					
Rated travel in mm		6 ¹⁾	6 ¹⁾	12	12	15	15	6 ¹⁾	6 ¹⁾	12	12	15	15
Thrust in N	Extends	500	700	700	700	700	700	700	700	700	700	700	700
	Retracts	-	-	-	-	700	700	-	-	-	-	700	700
Thrust in N in the event of fail-safe action		500	500	500	500	280	280	500	500	500	500	280	280
Manual override		✓ ²⁾						✓ ²⁾					
Stroking speed in mm/s (adjustable in version with positioner)													
	Slow	-	-	-	-	-	-	0.13	0.13	0.13	0.13	0.13	0.13
	Normal	0.18	0.18	0.18	0.18	0.18	0.18	0.2	0.2	0.2	0.2	0.2	0.2
	Fast	0.36	-	0.36	-	0.36	-	0.36	0.36	0.36	0.36	0.36	0.36
Transit time in s for rated travel													
	Slow	-	-	-	-	-	-	45	45	89	89	111	111
	Normal	35	35	70	70	90	90	31	31	61	61	76	76
	Fast	18	-	35	-	45	-	17	17	33	33	41	41
Transit time in s in the event of fail-safe action		4	4	6	6	7	7	4	4	6	6	7	7
Attachment	Force-locking	✓	✓	✓	✓	-	-	✓	✓	✓	✓	-	-
	Form-fit	-	-	-	-	✓	✓	-	-	-	-	✓	✓
Supply voltage													
	24 V (±10 %), 50 Hz	-	✓ ³⁾	-	✓ ³⁾	-	✓	-	-	-	-	-	-
	230 V (±10 %), 50/60 Hz ⁴⁾ Protection provided by electrical installation in the building	✓ ³⁾	-	✓ ³⁾	-	✓	-	-	-	-	-	-	-
	24 V (±10 %), 50 and 60 Hz	-	-	-	-	-	-	✓ ³⁾	-	✓ ³⁾	-	✓	-
	24 V DC (-10, +20 %)	-	-	-	-	-	-	✓ ⁵⁾	-	✓ ⁵⁾	-	✓ ⁵⁾	-
	100 to 240 V (tolerance 85 to 264 V), 50 to 60 Hz (tolerance 47 to 63 Hz)	-	-	-	-	-	-	-	✓	-	✓	-	✓
Input signal		-						0 to 10 V, R _i = 20 kΩ · 0 to 20 mA, R _i = 50 Ω					
Output signal		-						0 to 10 V, R _s = 1 kΩ					
Power consumption in VA		5 ⁶⁾	5	5 ⁶⁾	5	5 ⁶⁾	5	8 ⁷⁾	10	8 ⁷⁾	10	8 ⁷⁾	10
Torque switch, active switching output		Max. 240 V, max. 1 A						-					
Weight in kg		1 ⁸⁾	1	1 ⁸⁾	1	1 ⁸⁾	1	1	1	1	1	1	1
Additional equipment (cannot be retrofitted)													
	Two limit contacts, max. 240 V, max. 1 A, without contact protection ⁹⁾	✓	✓	✓	✓	✓	✓	✓	-	✓	-	✓	-
	Resistance transmitter ¹⁰⁾ 0 to 1000 Ω ±15 %, max. 200 mW (90 % of final value at rated travel)	✓	✓	✓	✓	✓	✓	-	-	-	-	-	-
Testing according to DIN EN 14597													

¹⁾ Actuators with 6 mm travel can also be used for valves with 7.5 mm travel.

²⁾ With 4 mm Allen key

³⁾ Voltage tolerance for actuators tested according to DIN EN 14597: -15/+10 %

⁴⁾ 60 Hz as special version

⁵⁾ When the fast stroking speed setting is selected, the supply voltage must not fall below the specified value.

⁶⁾ Power consumption doubles for version with faster motor

⁷⁾ Power consumption of 24 V DC version specified in W

⁸⁾ The weight of the version with faster motor is 0.25 kg heavier.

⁹⁾ Contact protection with suitable spark suppression must be fitted for the switching contact. Observe the manufacturer's specifications concerning the connected load to select the appropriate spark suppression. A fuse, which is suitable for the application's circuit, must be used for the short-circuit and overload protection.

¹⁰⁾ Not possible in actuator with faster motor

Table 4: Technical data · Type 5827-Exx, version with “actuator stem retracts” fail-safe action

Type 5827-E		11	12	21	22	31	32	14	15	24	25	34	35
Actuation		Three-step						Positioner					
Rated travel in mm		6 ¹⁾	6 ¹⁾	12	12	15	15	6 ¹⁾	6 ¹⁾	12	12	15	15
Thrust in N	Extends	500	500	500	500	280	280	500	500	500	500	280	280
	Retracts	-	-	-	-	280	280	-	-	-	-	280	280
Thrust in N in the event of fail-safe action		-	-	-	-	280	280	280	-	-	-	280	280
Manual override		✓ ²⁾						✓ ²⁾					
Stroking speed in mm/s (adjustable in version with positioner)													
	Slow	-	-	-	-	-	-	0.13	0.13	0.13	0.13	0.13	0.13
	Normal	0.18	0.18	0.18	0.18	0.18	0.18	0.2	0.2	0.2	0.2	0.2	0.2
	Fast	-	-	-	-	-	-	0.36	0.36	0.36	0.36	0.36	0.36
Transit time in s for rated travel													
	Slow	-	-	-	-	-	-	45	45	89	89	111	111
	Normal	35	35	70	70	90	90	31	31	61	61	76	76
	Fast	-	-	-	-	-	-	17	17	33	33	41	41
Transit time in s for fail-safe action		4	4	6	6	7	7	4	4	6	6	7	7
Attachment	Force-locking	✓	✓	✓	✓	-	-	✓	✓	✓	✓	-	-
	Form-fit	-	-	-	-	✓	✓	-	-	-	-	✓	✓
Supply voltage													
	24 V (±10 %), 50 Hz	-	✓	-	✓	-	✓	-	-	-	-	-	-
	230 V (±10 %), 50/60 Hz ³⁾ Protection provided by electrical installation in the building	✓	-	✓	-	✓	-	-	-	-	-	-	-
	24 V (±10 %), 50 and 60 Hz 24 V DC (-10, +20 %) ⁴⁾	-	-	-	-	-	-	✓	-	✓	-	✓	-
	100 to 240 V (tolerance 85 to 264 V), 50 to 60 Hz (tolerance 47 to 63 Hz)	-	-	-	-	-	-	-	✓	-	✓	-	✓
Input signal		-						0 to 10 V, R _i = 20 kΩ · 0 to 20 mA, R _i = 50 Ω					
Output signal		-						0 to 10 V, R _B = 1 kΩ					
Power consumption in VA		5	5	5	5	5	5	8 ⁵⁾	10	8 ⁵⁾	10	8 ⁵⁾	10
Torque switch, active switching output		Max. 240 V, max. 1 A						-					
Weight in kg		1	1	1	1	1	1	1	1	1	1	1	1
Additional equipment (cannot be retrofitted)													
	Two limit contacts, max. 240 V, max. 1 A, without contact protection ⁶⁾	✓	✓	✓	✓	✓	✓	✓	-	✓	-	✓	-
	Resistance transmitter 0 to 1000 Ω ±15 %, max. 200 mW (90 % of final value at rated travel)	✓	✓	✓	✓	✓	✓	-	-	-	-	-	-

¹⁾ Actuators with 6 mm travel can also be used for valves with 7.5 mm travel.

²⁾ With 4 mm Allen key

³⁾ 60 Hz as special version

⁴⁾ When the fast stroking speed setting is selected, the supply voltage must not fall below the specified value.

⁵⁾ Power consumption of 24 V DC version specified in W

⁶⁾ Contact protection with suitable spark suppression must be fitted for the switching contact. Observe the manufacturer's specifications concerning the connected load to select the appropriate spark suppression. A fuse, which is suitable for the application's circuit, must be used for the short-circuit and overload protection.

Table 5: Technical data · All versions

Type 5827-N/-A/-E	
Safety	
Degree of protection ¹⁾	IP54 according to EN 60529
Class of protection ¹⁾	II according to EN 61140
Degree of contamination	2 according to EN 60664-1
Noise immunity	According to EN 61000-6-2 and EN 61326-1
Noise emission	According to EN 61000-6-3 and EN 61326-1
Electrical safety	According to EN 60730-1 and EN 60730-2-14
Rated surge voltage	2.5 kV according to EN 60730-1
Vibration	According to EN 60068-2-64 and EN 60068-2-27
Conformity	CE · EAC
Materials	
Housing, housing cover	Plastic (PPO with glass fiber reinforcement)
Coupling nut M32x1.5	Brass
Ambient conditions	
Permissible temperature ranges ²⁾	
Ambient	0 to 50 °C
Storage	-20 to +70 °C
Humidity	5 to 95 % moisture, no dew formation
Max. altitude above sea level	2000 m

¹⁾ Only with closed and locked front housing cover

²⁾ The permissible medium temperature depends on the valve on which the actuator is mounted. The limits in the valve documentation apply.

Dimensions

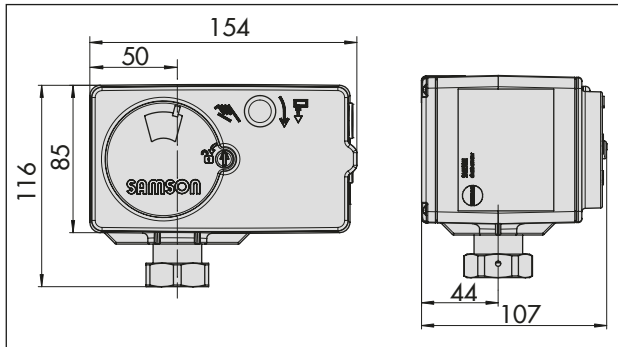

Fig. 8: Dimensions in mm · Force-locking attachment

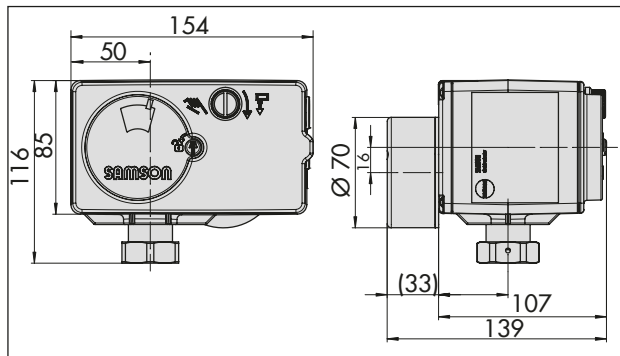

Fig. 10: Dimensions in mm · Actuator with faster motor, force-locking attachment

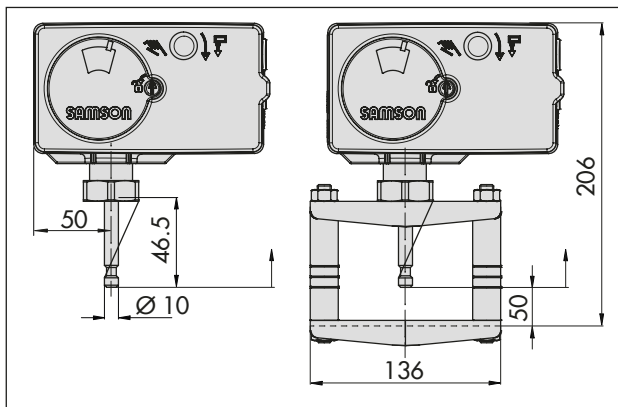

Fig. 9: Dimensions in mm · Form-fit attachment

Mounting position

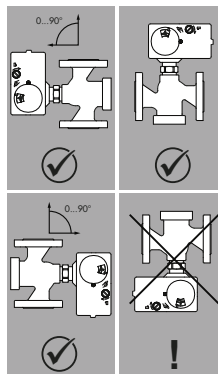
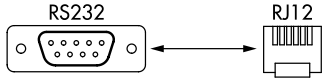





Fig. 11: Mounting position

Accessories

Accessories	Order no.
For version with positioner	
Hardware package consisting of: <ul style="list-style-type: none"> - Memory pen-64 - Connecting cable RJ-12/D-sub, 9 pin - Modular adapter 	1400-9998
Connecting cable RJ-12/D-sub, 9 pin	1400-7699 
Memory pen-64	1400-9753 
Modular adapter	1400-7698 
USB to RS-232 adapter	8812-2001 
Software	
TROVIS-VIEW (free of charge)	▶ www.samsongroup.com > DOWNLOADS > Software & Drivers > TROVIS-VIEW
For all versions	
Cable glands	
M16x1.5 cable gland for 4 to 8 mm clamping range	100243686
M16x1.5 cable gland for 5 to 10 mm clamping range	1402-9857
For mounting on form-fit valves without return spring ¹⁾	
Yoke for Series V2001 Valves	1400-7414
Spacer to mount the actuator on Type 3323 Valve (DN 65 to 80)	0340-3031

¹⁾ With Type 5827-x3x Electric Actuator

Ordering text

Type 5827-... Electric Actuator

- Version with three-step signal

Rated travel

6/12/15 mm

Normal/Fast

Supply voltage:

230 V, 50 Hz

230 V, 60 Hz (special version)

24 V, 50 Hz

Limit contacts: with/without

Resistance transmitter: with/without

- Version with digital positioner

Rated travel

6/12/15 mm

Supply voltage

24 V, 50/60 Hz and DC

85 to 264 V, 50 and 60 Hz

Limit contacts: with/without ¹⁾

¹⁾ 24 V version only

Associated mounting and operating instructions

- Type 5827 (version with three-step signal) ▶ EB 5827-1
- Type 5827 (version with positioner) ▶ EB 5827-2